



SPECIFICATIONS

GYPSUM ASSOCIATION

6525 Belcrest Road, Suite 480, Hyattsville, MD 20782

APPLICATION AND FINISHING OF GYPSUM PANEL PRODUCTS

GA-216-2016

National 
Gypsum®

TABLE OF CONTENTS

SECTION	PAGE
1. Scope and General Provisions	1
2. Definitions and Descriptions of Terms and Types of Materials for the Purposes of this Specification	1
3. Delivery, Identification, Handling, and Storage	4
4. Application of Gypsum Panel Products - General Provisions	5
5. Application of Single-Layer Gypsum Panel Products to Wood Framing Members	9
6. Application of Multi-Layer Gypsum Panel Products to Wood Framing Members	11
7. Adhesive Application to Wood Framing Members	11
8. Gypsum Panel Product Application over Steel Framing and Furring	12
9. Semi-Solid Gypsum Panel Products Partitions	13
10. Solid Gypsum Panel Products Partitions	13
11. Adhesive Application of Gypsum Panel Products to Interior Masonry, Concrete, or Brick Walls	14
12. Application of Gypsum Panel Products to Flat Wall Insulating Concrete Form (ICF) Systems	14
13. Application of Gypsum Panel Products over Existing Interior Walls and Ceilings	15
14. Gypsum Panel Product Application over Rigid Plastic Foam Insulation	16
15. Application of Rigid Predecorated Combustible Panels (Paneling) to Gypsum Substrate	16
16. Application of Gypsum Panel Products to Receive Adhesively Applied Ceramic or Plastic Wall Tile or Plastic Finished Wall Panels	16
17. Outside Corners, Arches, and Curves	18
18. Exterior Applications of Exterior Gypsum Soffit Board, or Gypsum Panel Products	18
19. Electric Radiant Heating Systems for Gypsum Panel Product Ceilings	19
20. Finishing Gypsum Panel Products	19
Appendix	21
A.1 Precautions to Minimize Potential of Sagging	21
A.2 Application of Ceramic or Plastic Wall Tile or Plastic Finished Wall Panels over Gypsum Panel Products	21
A.3 Application of Water-Based Texture Finishes on Gypsum Panel Product Ceilings	22
A.4 Decoration of Gypsum Panel Products	22

Characteristics, properties, or performance of materials or systems herein described are based on data obtained under controlled test conditions and are for defined architectural or engineering end users. The Gypsum Association and its member companies make no warranties or other representations as to their characteristics, properties, or performance under any variation from such conditions or in uses in actual construction.

LIST OF TABLES AND FIGURES

TABLES	PAGE
1 Maximum Framing Spacing For Single-Layer Gypsum Panel Product	4
2 Multi-Layer Application Without Adhesive Between Layers	5
3 Multi-Layer Application With Adhesive Between Layers	5
4 Maximum Weight of Overlaid Unsupported Insulation	6
5 Fastener Lengths For Gypsum Panel Product Application to Wood Framing	8
6 Base Layer Fastener Spacing for Multi-Layer Gypsum Panel Product Application	9
7 Fastener Spacing with Adhesive or Mastic Application and Supplemental Fastening	11
8 Bending Radii	18
9 Thermal Performance Values of Gypsum Board	19

FIGURES	PAGE
1 Typical resilient channels	3
2 Corner bead, trim, and casings	4
3 Typical joint locations at window openings	7
4 Typical control joint	8
5 Vertical section, ceiling framing oriented perpendicular to wall	10
6 Vertical section, ceiling framing oriented parallel to wall	10
7 Horizontal section through interior vertical angle	10
8 Single nailing	10
9 Double nailing	10
10 Adhesive application patterns	12
11 Direction of gypsum panel product application to steel framing	12
12 Typical gypsum panel vertical joint location relative to Insulating Concrete Form cross ties	14
13 Shimmed plaster wall	15
14 Gypsum panel product substrate under rigid predecorated combustible paneling	16
15 Typical details - tub installation	17
16 Typical details - shower pan installation	17
17 Typical details - tub installation in fire-rated or sound-rated system	17
18 Typical soffit details	19
19 Tile in bath and shower should be brought up to the levels shown	22

SPECIFICATIONS FOR THE APPLICATION AND FINISHING OF GYPSUM PANEL PRODUCTS

1. Scope and General Provisions.

1.1 These are specifications for the application and finishing of gypsum panel products and related items and accessories to interior walls and ceilings and to exterior soffits.

1.1.1 These specifications do not cover the application of gypsum sheathing, gypsum lath, or gypsum base for veneer plaster.

Note 1: Refer to GA-253, *Application of Gypsum Sheathing*; ASTM C841, *Standard Specification for Installation of Interior Lathing and Furring*; and ASTM C844, *Standard Specification for Application of Gypsum Base to Receive Gypsum Veneer Plaster*, for the application of these materials.

1.2 Where fire resistance, smoke resistance, or sound control is required for systems using gypsum panel products, the applicable building code regulations shall be followed. System details for fire and sound rated systems are described in the GA-600, *Fire Resistance Design Manual*.

1.3 Gypsum panel products shall not be used where there will be direct exposure to water or continuous high humidity conditions. Such areas include but are not limited to saunas, steam rooms, gang shower rooms, and indoor pools.

1.4 Gypsum panel products shall not be used where they will be exposed to sustained temperatures of more than 125°F (52°C) for extended periods of time.

1.5 Where gypsum panel products are used in air handling systems, the surface temperature of the gypsum panel products shall be maintained above the air stream dew point temperature but not more than 125°F (52°C).

1.6 Attics or similar unconditioned spaces above gypsum panel product ceilings shall be ventilated by providing cross ventilation for all spaces between the roof and the top floor ceiling.

2. Definitions and Descriptions of Terms and Types of Materials for the Purposes of this Specification.

2.1 Terminology.

2.1.1 Base Layer, *n* - The first layer of gypsum panel products applied in a multi-layer application.

2.1.2 Control (expansion-contraction) Joint, *n* - a designed separation in the system materials that allows for movement caused by expansion or contraction of the system.

2.1.3 Edge, *n* - bound edge, as manufactured.

2.1.4 End (butt), *n* - mill-cut or field-cut end perpendicular to the edge. At such cuts the gypsum core is exposed.

2.1.5 Fastener, *n* - nails, screws, or staples used for mechanical application of gypsum panel products.

2.1.6 Finishing, *v* - the act of concealing joints with joint compound and tape, and fastener heads and edges or flanges of accessories with joint compound.

2.1.7 Framing Member, *n* - that portion of framing, furring, bridging, blocking, etc., to which gypsum panel products are attached.

Note 2: Framing member as used herein includes the cross-tie flanges in Insulating Concrete Form (ICF) Systems.

2.1.8 Gypsum Board, *n* - Defined in ASTM C11, *Standard Terminology Relating to Gypsum and Related Building Materials and Systems*, as "the generic name for a family of sheet products consisting of a noncombustible core primarily of gypsum, with paper surfacing."

2.1.9 Gypsum Panel Products, *n* - Defined in ASTM C11, *Standard Terminology Relating to Gypsum and Related Building Materials and Systems*, as "the general name for a family of sheet products consisting essentially of gypsum."

2.1.10 Parallel Application, *n* - gypsum panel products applied with edges oriented parallel to framing members.

2.1.11 Perpendicular Application, *n* - gypsum panel products applied with edges oriented at right angles to framing members.

2.1.12 Skim Coat, *n* - either a thin coat of joint compound applied at a trowel consistency or a material manufactured specifically for this purpose, applied in accordance with manufacturer's recommendations over the entire surface.

Note 3: Refer to GA-214, *Recommended Levels of Finish for Gypsum Board, Glass Mat, and Fiber-Reinforced Gypsum Panels*, for further discussion of trowel consistency and skim coating operation.

2.1.13 Treated Joint, *n* - a joint between gypsum panel products that is reinforced with tape and joint compound, or covered by strip moldings.

2.1.14 Untreated Joint, *n* - a joint between gypsum panel products that is left exposed.

2.1.15 Additional definitions are contained in ASTM C11, *Standard Terminology Relating to Gypsum and Related Building Materials and Systems*.

2.2 Materials.

2.2.1 Types of Gypsum Board.

2.2.1.1 Gypsum Wallboard. Shall comply with ASTM C1396/C1396M, *Standard Specification for Gypsum Board*, Section 5, and CAN/CSA-A82.27M, *Gypsum Board*.

2.2.1.2 Gypsum Backing Board. Shall comply with ASTM C1396/C1396M, *Standard Specification for Gypsum Board*, Section 6, and CAN/CSA-A82.27M, *Gypsum Board*.

2.2.1.3 Gypsum Coreboard. Shall comply with ASTM C1396/C1396M, *Standard Specification for Gypsum Board*, Section 6, and CAN/CSA-A82.27M, *Gypsum Board*.

2.2.1.4 Gypsum Shaftliner Board. Shall comply with ASTM C1396/C1396M, *Standard Specification for Gypsum Board*, Section 6, and CAN/CSA-A82.27M, *Gypsum Board*.

2.2.1.5 Water-Resistant Gypsum Backing Board. Shall comply with ASTM C1396/C1396M, *Standard Specification for Gypsum Board*, Section 7, and CAN/CSA-A82.27M, *Gypsum Board*.

2.2.1.6 Exterior Gypsum Soffit Board. Shall comply with ASTM C1396/C1396M, *Standard Specification for Gypsum Board*, Section 8, and CAN/CSA-A82.27M, *Gypsum Board*.

2.2.1.7 Gypsum Ceiling Board. Shall comply with ASTM C1396/C1396M, *Standard Specification for Gypsum Board*, Section 13.

2.2.1.8 Type X (Special Fire Resistant) Gypsum Board. Gypsum board that provides greater fire resistance as defined in ASTM C1396/C1396M, *Standard Specification for Gypsum Board*.

2.2.1.9 Foil-Backed Gypsum Board. Shall be gypsum board with an aluminum foil vapor retarder laminated to the back surface.

2.2.2 Types of Fiber-Reinforced Gypsum Panels.

2.2.2.1 Interior Fiber-Reinforced Gypsum Panel. Shall comply with ASTM C1278/C1278M, *Standard Specification for Fiber-Reinforced Gypsum Panels*, Section 5.

2.2.2.2 Water-Resistant Fiber-Reinforced Gypsum Backing Panel. Shall comply with ASTM C1278/C1278M, *Standard Specification for Fiber-Reinforced Gypsum Panels*, Section 6.

2.2.2.3 Exterior Fiber-Reinforced Gypsum Soffit Panel. Shall comply with ASTM C1278/C1278M, *Standard Specification for Fiber-Reinforced Gypsum Panels*, Section 7.

2.2.2.4 Type X (Special Fire Resistant) Fiber-Reinforced Gypsum Panel. Fiber-Reinforced Gypsum Panels that provide greater fire resistance as defined in ASTM C1278/C1278M, *Standard Specification for Fiber-Reinforced Gypsum Panels*.

2.2.2.5 Foil-Backed Fiber-Reinforced Gypsum Panel. Shall be fiber-reinforced gypsum panels with an aluminum foil vapor retarder laminated to the back surface.

2.2.3 Types of Glass Mat Gypsum Panels

2.2.3.1 Glass Mat Interior Gypsum Panel. Shall comply with ASTM C1658/C1658M, *Standard Specification for Glass Mat Gypsum Panels*, Section 5.

2.2.3.2 Glass Mat Coreboard Gypsum Panel. Shall comply with ASTM C1658/C1658M, *Standard Specification for Glass Mat Gypsum Panels*, Section 6.

2.2.3.3 Glass Mat Shaftliner Gypsum Panel. Shall comply with ASTM C1658/C1658M, *Standard Specification for Glass Mat Gypsum Panels*, Section 6.

2.2.3.4 Glass Mat Water-Resistant Gypsum Panel. Shall comply with ASTM C1658/C1658M, *Standard Specification for Glass Mat Gypsum Panels*, Section 7.

2.2.3.5 Type X (Special Fire Resistant) Glass Mat Gypsum Panel. Glass Mat Gypsum Panels that provide greater fire resistance as defined in ASTM C1658/C1658M, *Standard Specification for Glass Mat Gypsum Panels*.

2.2.3.6 Coated Glass Mat Water-Resistant Gypsum Backing Board. Shall comply with ASTM C1178/C1178M, *Standard Specification for Coated Glass Mat Water-Resistant Gypsum Backing Panel*.

2.2.3.7 Type X (Special Fire Resistant) Coated Glass Mat Water-Resistant Gypsum Backing Board. Coated Glass Mat Gypsum Panels that provide greater fire resistance as defined in ASTM C1178/C1178M, *Standard Specification for Coated Glass Mat Water-Resistant Gypsum Backing Panel*.

2.2.4 Types of Factory-Laminated Gypsum Panel Products.

2.2.4.1 Factory-Laminated Gypsum Panel Products. Shall comply with ASTM C 1766, *Standard Specification for Factory-Laminated Gypsum Panels Products*.

2.2.4.2 Type X (Special Fire Resistant) Factory-Laminated Gypsum Panel Products. Factory-Laminated Gypsum Panels that provide greater fire resistance as defined in ASTM C1766, *Standard Specification for Factory-Laminated Gypsum Panels Products*.

2.2.5 Types of Impact and Abuse Resistant Gypsum Panel Products and Type X (Special Fire Resistant) Impact and Abuse Resistant Gypsum Panel Products. Shall be either Gypsum Board, Fiber-Reinforced Gypsum Panels, or Glass Mat Gypsum Panels complying with 2.2.1 through 2.2.3, and either 2.2.5.1 or 2.2.5.2.

2.2.5.1 Impact Resistant Gypsum Panel Products. Shall be classified in accordance with ASTM C1629, *Standard Classification for Abuse Resistant Nondecorated Interior Gypsum Panel Products and Fiber-Reinforced Cement Panels*.

2.2.5.2 Abuse Resistant Gypsum Panel Products. Shall be classified in accordance with ASTM C1629, *Standard Classification for Abuse Resistant Nondecorated Interior Gypsum Panel Products and Fiber-Reinforced Cement Panels*.

2.2.6 Joint Compound. Shall comply with *Standard Specification for Joint Compound and Joint Tape for Finishing Gypsum Board*, ASTM C475.

2.2.7 Water. Shall be clean, fresh, and suitable for domestic consumption.

2.2.8 Nails. Shall comply with ASTM C514, *Standard Specification for Nails for Application of Gypsum Board*. Special nails for predecorated gypsum panel products shall be as specified by the predecorated gypsum panel products manufacturer.

2.2.9 Screws.

2.2.9.1 Type G screws, for attaching gypsum panel products to gypsum panel products; Type S screws, for attaching gypsum panel products to nonstructural cold-formed steel framing and wood framing members; and Type W screws, for attaching gypsum panel products to wood framing members, shall comply with ASTM C1002, *Standard Specification for Steel Self-Piercing Tapping Screws for the Application of Gypsum Panel Products or Metal Plaster Bases to Wood Studs or Steel Studs*. Where Abuse Resistant or Impact Resistant Gypsum Panels are used, the screws used to attach the panels shall be either hi-low for steel or wood framing or coarse thread for wood framing.

2.2.9.2 Type S-12 screws, for attaching gypsum panel products, including abuse-resistant and impact-resistant gypsum panels, to structural cold-formed steel framing members not more than 0.112 in. (2.84 mm), shall comply with ASTM C954, *Standard Specification for Steel Drill Screws for the Application of Gypsum Panel Products or Metal Plaster Bases to Steel Studs from 0.033 in. (0.84 mm) to 0.112 in. (2.84 mm) in Thickness*.

2.2.10 Staples. Shall be No. 16 gauge, flattened, galvanized, divergent point wire staples with not less than 7/16 in. (11 mm) wide crown outside measure.

2.2.11 Adhesives.

2.2.11.1 Adhesives for attaching gypsum panel products to wood framing members shall comply with either ASTM C557, *Standard Specification for Adhesives for Fastening Gypsum Wallboard to Wood Framing*, or ASTM D6464, *Standard Specification for Expandable Foam Adhesives for Fastening Gypsum Wallboard to Wood Framing*.

2.2.11.2 Adhesives for attaching gypsum panel products to steel framing members shall be as specified by the adhesive manufacturer.

2.2.11.3 Laminating Adhesive. Shall be joint compound complying with ASTM C475, *Standard Specification for Joint Compound and Joint Tape for Finishing Gypsum Board*, or other laminating adhesives specified by gypsum panel product manufacturer. Joint compounds used for laminating shall be taping, all-purpose, or setting-type joint compounds.

2.2.12 Framing Members.

2.2.12.1 Wood framing members shall be of the proper grade for the intended use and shall comply with DOC Voluntary Product Standard PS 20, *American Softwood Lumber Standard*, or CAN/CSA-O141, *Softwood Lumber*.

2.2.12.2 Engineered wood products. Refer to the manufacturer of the engineered wood product.

2.2.12.3 Nonstructural cold-formed steel framing members, including furring channels, shall be not less than 0.0179 in. (0.455 mm) steel and shall comply with ASTM C645, *Standard Specification for Nonstructural Steel Framing Members*.

2.2.12.4 Where studs complying with ASTM C645 are used to receive Abuse Resistant or Impact Resistant Gypsum panels, they shall be not less than 0.0312 in. (0.792 mm) base metal thickness and shall be in accordance with sections 4.3 and 8.1 of Specification C645.

2.2.12.5 Steel framing members from 0.033 in. (0.84 mm) to 0.112 in. (2.84 mm) shall comply with ASTM C955, *Standard Specification for Load-Bearing (Transverse and Axial) Steel Studs, Runners (Tracks), and Bracing or Bridging for Screw Application of Gypsum Panel Products and Metal Plaster Bases*.

2.2.12.6 Resilient furring channels. See Figure 1.

Figure 1
Typical resilient channels

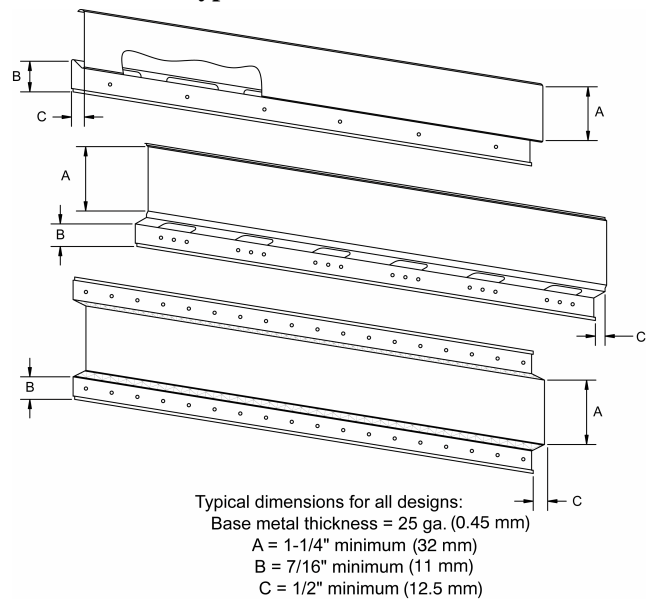

2.2.12.7 Gypsum studs shall be not less than 6 in. (150 mm) wide and 1 in. (25.4 mm) thick and of lengths approximately 6 in. (150 mm) less than the floor-to-ceiling height unless full-height lengths are required for fire stops or for fire resistance. They shall be of either 1 in. (25.4 mm) gypsum panel products or multi-layer gypsum panel products laminated to the required thickness.

2.2.12.8 Flat Wall Insulating Concrete Form (ICF) Systems shall comply with ASTM E2634, *Standard Specification for Flat Wall Insulating Concrete Form (ICF) Systems*.

2.2.13 Accessories. Shall comply with ASTM C1047, *Standard Specification for Accessories for Gypsum Wallboard and Gypsum Veneer Base*. Flanges shall be free from dirt, grease, or other material that adversely affects the bond of joint treatment or decoration.

2.2.13.1 Designations used to identify commonly specified types of metal trim and casings are shown in Figure 2.

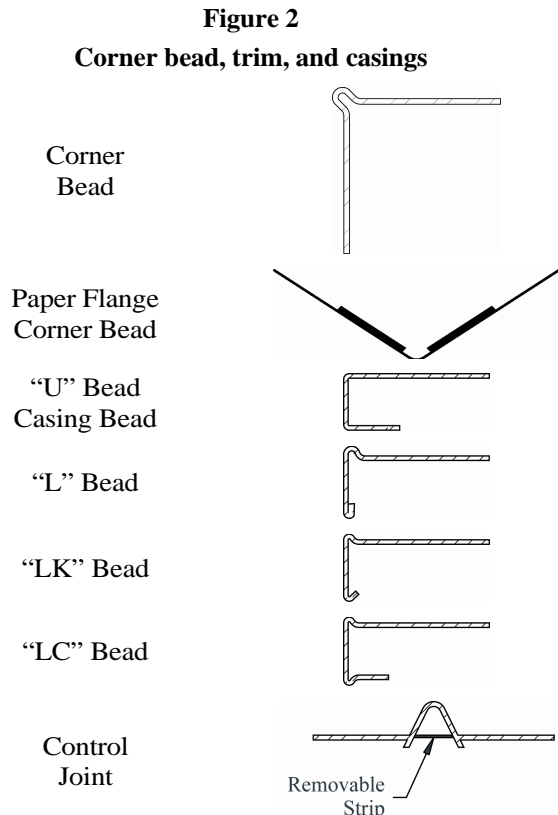

2.2.13.2 Other types of corner, edge trim, decorative dividers, or control joints between gypsum panel products shall be permitted to be used when they comply with the general provisions of Section 2.2.14.

3. Delivery, Identification, Handling, and Storage.

3.1 Gypsum panel products, except for predecorated gypsum board, are intended to be a substrate. The surfaces of gypsum panel products shall be true and free from imperfections that would render them unfit for finishing and final decoration.

3.2 All materials shall be delivered in original bundles bearing the brand name, if any; applicable standard designation; and name of the manufacturer or supplier for whom the product is manufactured.

3.2.1 The plastic packaging used to wrap gypsum panel products for rail and/or truck shipment is intended to provide temporary protection from moisture exposure during transit only and is not intended to provide protection during storage after delivery. Such plastic packaging shall be removed immediately upon receipt of the shipment.

Note 4: Failure to remove protective plastic shipping covers can result in condensation, leading to damage, including mold.

3.3 All materials shall be kept dry. Gypsum panel products shall be neatly stacked flat with care taken to prevent sagging or damage to edges, ends, and surfaces.

3.3.1 Gypsum panel products and accessories shall be properly supported on risers on a level platform, and fully protected from weather, direct sunlight exposure, and condensation.

3.4 Gypsum panel products shall be stacked flat rather than on edge or end. Gypsum panel products stacked on edge or end can be unstable and present a serious hazard in the workplace should they accidentally topple.

3.5 Refer to GA-801, *Handling and Storage of Gypsum Panel Products: A Guide for Distributors, Retailers, and Contractors*, for proper storage and handling requirements.

Table 1 Maximum Framing Spacing For Single-Layer Gypsum Panel Product		
Gypsum Panel Product Thickness in. (mm)	Gypsum Panel Product Orientation to Framing	Maximum Framing Spacing in. (mm) o.c.
Ceilings:		
3/8 (9.5) ^A	Perpendicular ^B	16 (406)
1/2 (12.7)	Parallel ^B	16 (406)
1/2 (12.7)	Perpendicular ^B	24 (610)
5/8 (15.9)	Parallel	16 (406)
5/8 (15.9)	Perpendicular	24 (610)
Walls:		
3/8 (9.5)	Perpendicular or Parallel	16 (406)
1/2 (12.7)	Perpendicular or Parallel	24 (610)
5/8 (15.9)	Perpendicular or Parallel	24 (610)
<p>^A Shall not support thermal insulation.</p> <p>^B On ceilings to receive water-based texture material either i) 1/2 in. (12.7 mm) gypsum ceiling board shall be applied perpendicular to framing; or ii) other gypsum panel products shall be applied perpendicular to framing and board thickness shall be increased from 3/8 in. (9.5 mm) to 1/2 in. (12.7 mm) for 16 in. (406 mm) o.c. framing and from 1/2 in. (12.7 mm) to 5/8 in. (15.9 mm) for 24 in. (610 mm) o.c. framing. (See Appendix A.3.)</p>		

4. Application of Gypsum Panel Products - General Provisions.

4.1 Framing. The requirements of Sections 4.1.1 through 4.1.8 shall be followed to provide a proper base to receive gypsum panel products.

4.1.1 Steel framing members shall be straight. Bent, twisted, or damaged framing members shall not be used. Steel framing members shall be installed in accordance with ASTM C754, *Standard Specification for Installation of Steel Framing Members to Receive Screw-Attached Gypsum Panel Products*, or ASTM C1007, *Standard Specification for Installation of Load Bearing (Transverse and Axial) Steel Studs and Related Accessories*.

4.1.2 Wood framing members to which gypsum panel products are to be attached shall be straight and true.

4.1.3 Where gypsum panel products are nailed to wood cross furring on ceilings, those furring members shall be not less than 1 1/2 in. x 1 1/2 in. (38 mm x 38 mm) actual size and shall be spaced as specified in Tables 1, 2, and 3. Where screw application is used, wood furring members shall be not less than 3/4 in. x 1 1/2 in. (19 mm x 38 mm) actual size.

4.1.4 Where wood furring is used over solid surfaces, wood furring members shall be not less than 3/4 in. x 1 1/2 in. (19 mm x 38 mm) actual size.

4.1.5 Unless otherwise specified herein, the surface to which abutting gypsum panel product edges or ends are attached shall be not less than 1 1/2 in. (38 mm) wide for wood framing members, 1 1/4 in. (32 mm) wide for steel framing members, and 6 in. (150 mm) wide for gypsum studs. At internal corners or angles, bearing surfaces shall be not less than 3/4 in. (19 mm).

4.1.6 Where rigid furring channels are used with wood framing, channels shall be spaced not more than 24 in. (610 mm) o.c. and shall be applied at right angles to wall and ceiling framing members. Channels shall be located not more than 2 in. (50 mm) from the floor and not more than 6 in. (150 mm) from the wall/ceiling intersection. Channels shall be attached through alternating flanges to each framing member with either 6d nails, 1 7/8 in. (48 mm) long, or 1 1/4 in. (32 mm) Type S or W drywall screws.

4.1.7 Where resilient furring channels are used with wood framing, channels shall be spaced not more than 24 in. (610 mm) o.c. and shall be applied at right angles to wall and ceiling framing members. Channels shall be located not more than 2 in. (50 mm) from the floor and not more than 6 in. (150 mm) from the ceiling. Channels shall be attached as specified in 4.1.7.1 or 4.1.7.2.

Table 2 Multi-Layer Application Without Adhesive Between Layers				
Gypsum Panel Product Thickness in. (mm)		Gypsum Panel Product Orientation to Framing		Maximum Framing Spacing in. (mm) o.c.
Base	Face	Base	Face	
Ceilings				
1/4 (6.4)	3/8 (9.5)	Perpendicular	Perpendicular*	16 (406)
1/4 (6.4)	1/2 (12.7)	Perpendicular	Perpendicular*	16 (406)
3/8 (9.5)	3/8 (9.5)	Perpendicular	Perpendicular*	16 (406)
3/8 (9.5)	1/2 (12.7)	Perpendicular	Perpendicular*	16 (406)
1/2 (12.7)	3/8 (9.5)	Parallel	Perpendicular*	16 (406)
1/2 (12.7)	1/2 (12.7)	Parallel	Perpendicular	16 (406)
1/2 (12.7)	1/2 (12.7)	Perpendicular	Perpendicular*	24 (610)
1/2 (12.7)	5/8 (15.9)	Perpendicular	Perpendicular	24 (610)
5/8 (15.9)	1/2 (12.7)	Perpendicular	Perpendicular*	24 (610)
5/8 (15.9)	5/8 (15.9)	Perpendicular	Perpendicular	24 (610)
Walls:				
For multi-layer application with no adhesive between layers 1/2 in. (12.7 mm) or 5/8 in. (15.9 mm) thick gypsum panel products shall be permitted to be applied either perpendicular or parallel on framing spaced not more than 24 in. (610 mm) o.c. Framing spacing shall not be more than 16 in. (406 mm) o.c. when 3/8 in. (9.5 mm) thick gypsum panel products are used.				
* On ceilings to receive water-based texture material either i) 1/2 in. (12.7 mm) gypsum ceiling board shall be applied perpendicular to framing; or ii) other gypsum panel products shall be applied perpendicular to framing and board thickness shall be increased from 3/8 in. (9.5 mm) to 1/2 in. (12.7 mm) for 16 in. (406 mm) o.c. framing and from 1/2 in. (12.7 mm) to 5/8 in. (15.9 mm) for 24 in. (610 mm) o.c. framing. (See Appendix A.3.)				

Table 3 Multi-Layer Application With Adhesive Between Layers*				
Gypsum Panel Product Thickness in. (mm)		Gypsum Panel Product Orientation to Framing		Maximum Framing Spacing in. (mm) o.c.
Base	Face	Base	Face	
Ceilings				
3/8 (9.5)	3/8 (9.5)	Perpendicular	Parallel or Perpendicular	16 (406)
1/2 (12.7)	3/8 (9.5)	Parallel or Perpendicular	Parallel or Perpendicular	16 (406)
1/2 (12.7)	1/2 (12.7)	Parallel or Perpendicular	Parallel or Perpendicular	16 (406)
5/8 (15.9)	1/2 (12.7)	Parallel	Parallel or Perpendicular	24 (610)
5/8 (15.9)	5/8 (15.9)	Parallel or Perpendicular	Parallel or Perpendicular	24 (610)
Walls:				
For multi-layer application with adhesive between layers 3/8 in. (9.5 mm), 1/2 in. (12.7 mm), or 5/8 in. (15.9 mm) thick gypsum panel products shall be permitted to be applied either perpendicular or parallel on framing spaced not more than 24 in. (610 mm) o.c.				
* Adhesive between layers shall be dry or cured prior to the application of any decorative treatment.				

4.1.7.1 Hat-shaped (double-flanged) resilient channels shall be attached through alternating flanges to each framing member with either 1 1/4 in. (32 mm) Type S or W drywall screws, or 6d nails, 1 7/8 in. (48 mm) long.

4.1.7.2 Single-flanged resilient channels shall be attached through the mounting flange to each framing member with either 1 1/4 in. (32 mm) Type S or W drywall screws, or 6d nails, 1 7/8 in. (48 mm) long.

(a) On ceilings, single-flanged resilient channels shall be oriented with the mounting flanges facing the same direction.

(b) On walls, single-flanged channels shall be installed with the mounting flange down. The channel at the floor shall be inverted as necessary to facilitate attachment of base molding.

4.1.8 The attachment surface of any framing or furring member shall not vary more than 1/8 in. (3 mm) from the plane of the faces of adjacent framing or furring members.

4.1.9 Spacing of framing or furring members shall be as specified in Table 1.

4.1.10 Framing and furring members shall be as required to meet design or building code loading requirements.

4.1.11 Deflection at design load of horizontal (ceiling) framing or furring members supporting gypsum panel products shall be not more than L/240 of the span.

4.1.12 Additional supports shall be provided for support of fixtures.

of framing members to which gypsum panel products are to be attached.

4.2.2 During periods of cold or damp weather, when vapor retarder sheeting is installed on ceilings behind the gypsum panel product, the ceiling batt or blanket insulation shall be installed BEFORE the gypsum panel product is installed. Failure to follow this procedure creates a potential for moisture condensation on the back side of the gypsum panel product and possible ceiling sag. (See Appendix A.1.)

4.2.2.1 When loose-fill insulation is used above the ceiling, the attic insulation shall be installed immediately after the ceiling panel product is applied and before gypsum panel product joints are taped or any other wet finishing operations are begun on the walls or ceiling.

4.2.2.2 When thermal insulation installed above ceilings is supported by the gypsum panel product ceiling membrane, the weight of the overlaid insulation shall not exceed the maximum weight shown in Table 4 for the gypsum panel product type, thickness, number of layers, and framing spacing. Consult insulation supplier for insulation weight information.

4.3 Application Environmental Limitations.

4.3.1 Gypsum board shall be protected from direct exposure to rain, snow, sunlight, or other excessive weather conditions.

4.3.2 Ready-mixed joint compounds shall be protected from freezing, exposure to extreme heat, and direct sunlight.

4.3.3 Where materials are being mixed or used for joint treatment or for laminating gypsum panel products the room temperature shall be maintained at not less than 50°F (10°C) for a period beginning not less than 48 hours before mixing or application and continuing until applied materials are thoroughly dry.

4.3.4 The room temperature shall be maintained at not less than 40°F (4°C) for mechanical application of gypsum panel products and at not less than 50°F (10°C) for adhesive application of gypsum panel products and for joint treatment, texturing, and decoration unless otherwise specified by the manufacturer.

4.3.4.1 When a temporary heat source is used the temperature shall be not more than 95°F (35°C) in any given room or area.

4.3.4.2 When portable gas or kerosene heaters are used, the extra humidity that they produce shall be removed.

4.3.4.3 Adequate and continuous ventilation shall be provided in the working area during the installation and the drying or setting period.

4.4 Foil-Backed Gypsum Panel Products.

4.4.1 Foil-backed gypsum panel products shall be applied with the reflective surface facing the framing members or other substrate so that it is not exposed after application.

4.4.1.1 Foil-backed gypsum panel products shall not be used as a substrate for wall tile.

Gypsum Board Type	Thickness in. (mm)	Number of Layers of Gypsum	Maximum Insulation Weight psf (kg/m ²)
Gypsum Wallboard Gypsum Backing Board Exterior Gypsum Soffit Board	1/2 (12.7)	Single	1.6 ^B (7.8)
		Double	3.2 ^C (15.6)
Gypsum Base for Veneer Plaster	5/8 (15.9)	Single	2.2 (10.7)
		Double	4.4 (21.5)
Gypsum Ceiling Board	1/2 (12.7)	Single	2.2 (10.7)
		Double	4.4 (21.5)

^A Based on ceiling framing spaced 24 in. (610 mm) o.c.
^B Where ceiling framing is spaced 16 in. (406 mm) o.c. the maximum weight shall not exceed 2.2 psf (10.7 kg/m²).
^C Where ceiling framing is spaced 16 in. (406 mm) o.c. the maximum weight shall not exceed 4.4 psf (21.5 kg/m²).

4.1.13 Flat Wall Insulating Concrete Form (ICF) Systems shall be installed, filled with concrete, and cured in accordance with the ICF manufacturer's specifications.

4.2 Insulation.

4.2.1 Insulation batts and blankets or the flanges of insulation batts and blankets shall not be applied to the face

Figure 3
Typical joint locations at window openings

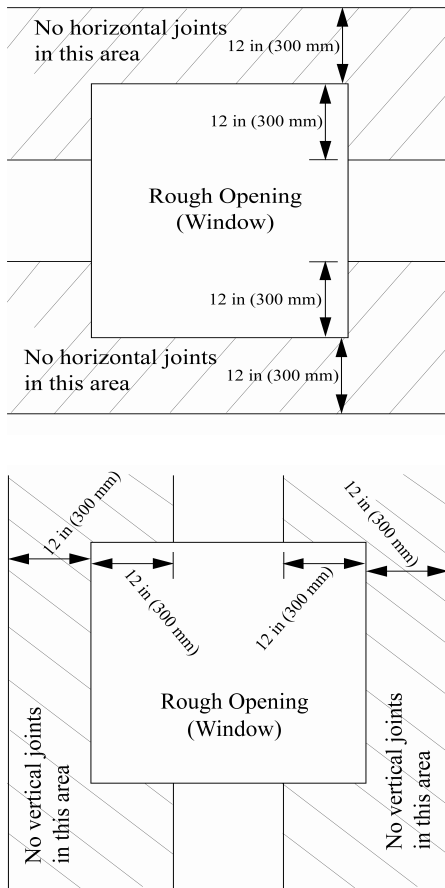

4.4.1.2 Foil-backed gypsum panel products shall not be used as the second or subsequent layer in a multi-layer laminated system.

4.4.1.3 Foil-backed gypsum panel products shall not be laminated directly to masonry.

4.4.1.4 Foil-backed gypsum panel products shall not be used in conjunction with electric heating cables or electric radiant heating systems.

4.4.2 Except where prohibited in Sections 4.4.1.1 through 4.4.1.4, foil-backed gypsum panel products shall be permitted to be used where a vapor retarder is required.

4.5 Cutting Gypsum Panel Products.

4.5.1 Gypsum panel products shall be cut either by scoring and breaking or by sawing, working from the face side. When scoring, a sharp knife shall be used to cut through the gypsum panel product face and into the core. The gypsum panel product shall then be snapped back away from the cut face. The back liner, if any, shall be cut or shall be broken by snapping the gypsum panel product in the reverse direction.

4.5.1.1 All cut edges and ends shall be smoothed as necessary to obtain neat fitting joints. (See Section 4.6.7.)

4.5.2 Holes, such as those for pipes, fixtures, or other penetrations, shall either be scored on both the face and back before removal of the cut-out with a saw or cut out with a router or other special tool designed for this purpose.

4.5.3 Where gypsum panel products meet projecting surfaces, the gypsum panel product shall be scribed and neatly cut.

4.6 Installation and Layout.

4.6.1 Gypsum panel products shall be applied first to ceilings and then to walls.

4.6.2 Gypsum panel product, 1/4 in. (6.4 mm) thick, shall not be used in single-ply applications on either walls or ceilings.

4.6.3 Ends or edges of gypsum panel products located at ceiling perimeter shall be permitted to be cantilevered, without blocking, not more than 2 in. (50mm) to the wall where ceiling framing is parallel to the wall.

4.6.4 Gypsum panel product joints shall be located so that no joint will occur within 12 in. (300 mm) of the corner of a window or door opening unless control joints are to be installed at these locations. (See Figure 3.)

4.6.5 Joints on opposite sides of a partition shall not occur on the same stud.

4.6.6 All ends and edges of gypsum panel products, except those described in Sections 4.6.6.1, 4.6.6.2, and 4.6.6.3, shall be located over framing members or other solid backing.

4.6.6.1 Treated or untreated gypsum panel product joints oriented at right angles to wall or ceiling framing members need not be located over framing or other solid backing.

4.6.6.2 Gypsum panel product edges or ends, oriented at right angles to wall framing, that occur above ceilings when the gypsum panel product is terminated at less than the full height of the framing need not be located over framing or other solid backing.

4.6.6.3 Where adhesives are used between layers in multi-layer gypsum panel product systems, joints in the second and subsequent layers need not be located over framing members.

4.6.7 In single layer gypsum panel product systems, end joints parallel to and on the same side of framing members shall be staggered between alternate courses of gypsum panel products and from joints on the opposite side of the framing members.

4.6.8 In multi-layer gypsum panel product systems, end joints parallel to and on the same side of framing members shall be staggered between alternate courses of gypsum panel products.

4.6.8.1 Base layer end joints parallel to and on one side of framing shall be staggered from base layer end joints on the opposite side of the framing members.

4.6.8.2 Where adjacent layers are applied in the same direction, either parallel or perpendicular application, joints shall be offset between layers. Horizontal joints shall be offset not less than 12 in. (300 mm) and vertical joints shall be offset not less than one cavity space.

4.6.9 Gypsum panel products shall be abutted so as to be in contact with one another but not forced together.

4.6.10 Where gaps occur at gypsum panel product joints, they shall be not greater than 1/4 in. (6 mm) and shall be prefilled with joint compound as specified in Sections 4.6.10.1 and 4.6.10.2.

4.6.10.1 Gaps not greater than 1/8 in. (3 mm) shall be prefilled with either drying-type or setting-type joint compound.

4.6.10.2 Gaps greater than 1/8 in. (3 mm) shall be prefilled with setting-type joint compound.

4.6.11 Gypsum panel products applied to walls shall be applied with the bottom edge spaced a minimum of 1/4 in. (6 mm) above the floor.

4.6.12 Gypsum panel products used in building construction shall be not less than 8 in. (200 mm) from the finish grade in fully weather and water protected siding systems, and in properly drained and ventilated crawl spaces. All cut edges shall be protected from water and moisture. The ground's surface in the crawl space shall be covered with a Class I vapor retarder.

4.7 Control Joints. (See Figure 4.)

4.7.1 Control joints shall be either manufactured devices designed for this purpose or field fabricated from suitable materials.

4.7.1.1 Full height door frames shall be considered equivalent to a control joint.

4.7.2 Control joints shall be installed where indicated on the plans.

4.7.3 Control joints in the gypsum panel products shall be specified by the architect or designer where any of the conditions described in Sections 4.7.3.1 through 4.7.3.7 exist.

4.7.3.1 A control joint shall be installed where a partition, wall, or ceiling traverses a construction joint (expansion, seismic, or building control element) in the base building structure.

4.7.3.2 Control joints shall be installed where a wall or partition runs in an uninterrupted straight plane exceeding 30 linear feet (9 m).

4.7.3.3 Control joints in direct applied interior ceilings, and suspended ceilings without perimeter relief, shall be installed so that linear dimensions between control joints do not exceed 30 ft (9 m).

4.7.3.4 Control joints in suspended ceilings with perimeter relief shall be installed so that linear dimensions between control joints do not exceed 50 ft (15 m).

4.7.3.5 Control joints in exterior ceilings and soffits shall be installed so that linear dimensions between control joints do not exceed 30 ft (9 m).

Figure 4
Typical control joint

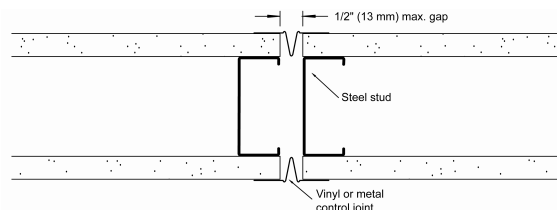

4.7.3.6 A control joint or intermediate blocking shall be installed where ceiling framing members change direction.

4.7.3.7 Control joints shall be installed where specified by the architect or designer as a design accent or architectural feature.

4.7.4 Where a control joint occurs in an acoustical or fire-rated system, other than ICF, blocking shall be provided behind the control joint by using a backing material such as 5/8 in. (15.9 mm) type X gypsum panel products, mineral fiber, or other tested equivalent. See GA-600, *Fire Resistance Design Manual*, or GA-234, *Control Joints for Fire-Resistance Rated Systems*.

4.8 Fasteners.

4.8.1 Fastener lengths shall be as specified in Table 5 for wood framing and Section 8.3 for metal framing.

Table 5
Fastener Lengths for Gypsum Panel Product Application to Wood Framing^A

Gypsum Panel Product Thickness ^B in. (mm)	Minimum Nail Length in. (mm)	Minimum Screw Length in. (mm)	Minimum Staple ^C Length in. (mm)
1/4 (6.4)	<i>D</i>	<i>D</i>	<i>D</i>
3/8 (9.5)	1-1/4 (32)	1 (25)	1 (25)
1/2 (12.7)	1-3/8 (35)	1-1/8 (28)	1-1/8 (28)
5/8 (15.9)	1-1/2 (38)	1-1/4 (32)	1-1/4 (32)

^A Where fire resistance is required for gypsum panel product systems, fasteners of the same or larger length, shank diameter, and head bearing area as those described in the fire-rated design shall be used.

^B For other thicknesses, for multi-layer applications, or for application over rigid foam insulation fasteners shall be of sufficient length to penetrate framing not less than 3/4 in. (19 mm) for nails, 5/8 in. (15 mm) for screws, and 5/8 in. (16 mm) for staples.

^C Staple attachment is restricted to base layers of multi-layer systems only. (See Section 4.8.4.)

^D For application over existing solid surfaces or in multi-layer applications, fastener shall be of sufficient length to penetrate framing not less than 3/4 in. (19 mm) for nails, 5/8 in. (16 mm) for screws.

4.8.1.1 Where shims are used over framing, fastener length shall be increased by not less than the total thickness of the shim.

4.8.2 Fasteners at gypsum panel product edges or ends shall be located not less than 3/8 in. (10 mm) from the edge or end. Except as specified in Section 4.9, fasteners at edges or ends in a perpendicular application shall be located not more than 1 in. (25 mm) from the edge or end. Perimeter attachment into partition top and bottom (sole) plates is neither required nor recommended except where fire ratings, structural performance requirements, or other special conditions require such attachment.

4.8.3 Staple attachment shall be restricted to the base layers of gypsum panel products in multi-layer systems only.

4.8.4 Gypsum panel products shall be held in firm contact with framing members or underlying support when driving fasteners. Application of fasteners shall proceed from the center or field of the gypsum panel product toward the ends and edges, or shall begin along one edge and proceed toward the other edge.

4.8.4.1 Nails shall be driven so that nail heads are slightly below the surface of the gypsum panel product without breaking the face paper or fracturing the core.

4.8.4.2 Screws shall be driven so that screw heads are slightly below the gypsum panel product surface without breaking the face paper, fracturing the core, or stripping the framing member around the screw shank.

4.8.4.3 Staples shall be driven with crowns parallel to framing members. Staples shall be driven so that crowns bear tightly against the gypsum panel product without cutting into the face paper or fracturing the core.

4.8.5 Fastener type and spacing for fire resistance rated assemblies shall be in accordance to the specified fire rated design.

4.9 Floating Interior Angles.

4.9.1 The floating angle method of application shall be permitted to be used to minimize the effects of truss uplift and the possibility of fastener popping in areas adjacent to wall and ceiling intersections. This method is applicable where either single nailing, double nailing, or screw attachment to wood framing is used. (See Figures 5, 6, and 7.)

4.9.2 Ceiling-Wall Intersections. (See Figures 5 and 6.)

4.9.2.1 The first fastener into each ceiling framing member, framed either perpendicular or parallel to the wall, shall be located not more than 7 in. (180 mm) out from the intersection for single nailing and not more than 12 in. (300 mm) for either screw application or double nailing.

4.9.2.2 The gypsum panel products on the wall shall be applied to provide firm support for the floated edges of the gypsum panel product on the ceiling. The uppermost fastener into each stud shall be located not more than 8 in. (200 mm) down from the ceiling intersection for single nailing and not more than 12 in. (300 mm) for either screw application or double nailing. (See Figures 5 and 6.)

4.9.3 Inside Corners of Walls. (See Figure 7.)

4.9.3.1 The overlapping gypsum panel product shall be applied so as to bring the back of the underlying gypsum panel product into firm contact with the face of the framing member behind it.

4.9.4 Special clips designed to provide support at wall corners and wall-ceiling intersections in lieu of back-up studs or blocking shall be permitted where approved.

4.9.5 Floating interior angles shall not be used where fire ratings or shear values are required.

5. Application of Single-Layer Gypsum Panel Products to Wood Framing Members.

5.1 Spacing of framing members for single-layer gypsum panel product construction shall be as specified in Table 1.

5.1.1 For spacing of framing members for gypsum ceiling board see note *B* in Table 1.

Table 6
Base Layer Fastener Spacing for Multi-Layer Gypsum Panel Product Application*

Location	Framing Spacing in.(mm)	Base Layer Nail Spacing in. (mm)		Base Layer Screw Spacing in. (mm)		Base Layer Staple Spacing in. (mm)	
		Where Face Layer is Laminated	Where Face Layer is Mechanically Attached	Where Face Layer is Laminated	Where Face Layer is Mechanically Attached	Where Face Layer is Laminated	Where Face Layer is Mechanically Attached
Walls	16 (406)	8 (200)	24 (600)	16 (400)	24 (600)	7 (180)	16 (400)
	24 (610)	8 (200)	24 (600)	12 (300)	24 (600)	7 (180)	16 (400)
Ceilings	16 (406)	7 (180)	16 (400)	12 (300)	24 (600)	7 (180)	16 (400)
	24 (610)	7 (180)	16 (400)	12 (300)	24 (600)	7 (180)	16 (400)

* Fastener spacing for the face layer in multi-layer systems shall be as specified in Sections 5.2 through 5.5 for single-layer systems.

Figure 5
Vertical section, ceiling framing oriented perpendicular to wall

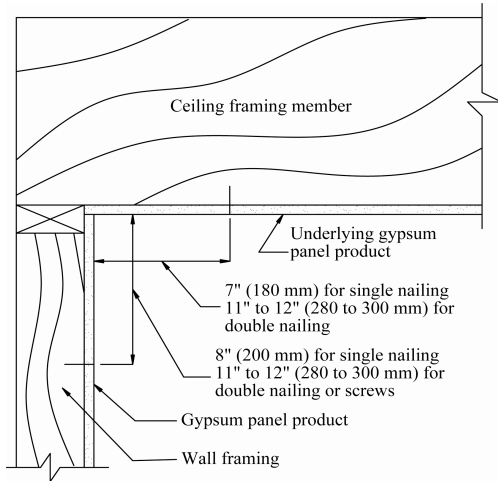

Figure 6
Vertical section, ceiling framing oriented parallel to wall

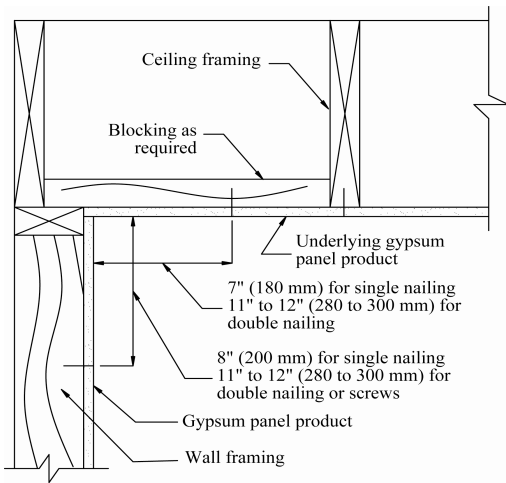
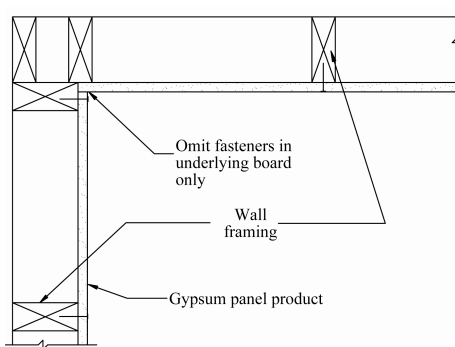

Figure 7
Horizontal section through interior vertical angle



5.2 Nails for single nailing shall be spaced not more than 7 in. (180 mm) o.c. on ceilings and not more than 8 in. (200mm) o.c. on walls. (See Figure 8.)

5.3 Nails for double nailing shall be spaced as shown in Figure 9 and applied as specified in Sections 5.3.1 through 5.3.5.

5.3.1 Starting at the center of the gypsum panel product, the first set of nails, shown by solid dots, shall be applied in row 1 first, then in rows 2 and 2A, then in rows 3 and 3A, then in rows 4 and 4A, etc. Nailing shall always proceed from the center to the ends and edges of the gypsum panel product.

Figure 8
Single nailing

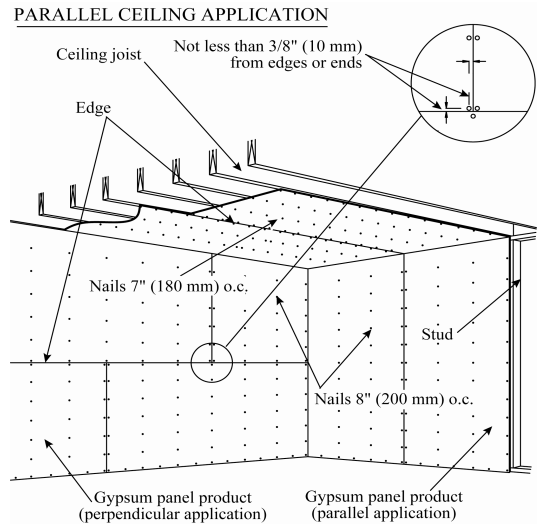
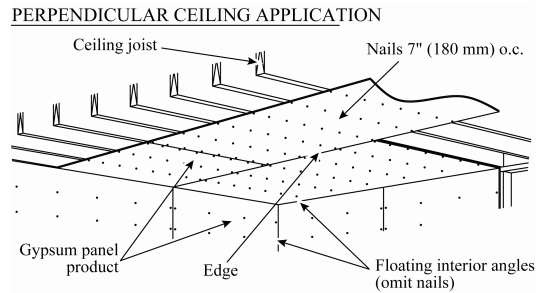

Figure 9
Double nailing

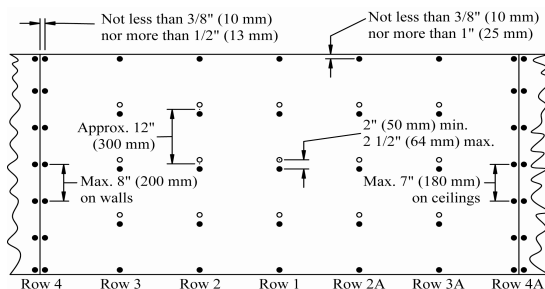

Table 7
Fastener Spacing with Adhesive or Mastic Application and Supplemental Fastening

Framing Spacing in. (mm)	Ceilings		Load-Bearing Partitions		Nonload-Bearing Partitions	
	Nail Spacing in. (mm)	Screw Spacing in. (mm)	Nail Spacing in. (mm)	Screw Spacing in. (mm)	Nail Spacing in. (mm)	Screw Spacing in. (mm)
16 (406)	16 (400)	16 (400)	16 (400)	24 (600)	24 (600)	24 (600)
24 (610)	12 (300)	16 (400)	12 (300)	16 (400)	16 (600)	24 (600)

5.3.2 The second set of nails, shown by circles, shall be applied in the same sequence as the first set of nails, starting with row 1.

5.3.3 As an alternate procedure, the second set of nails in each row shall be applied immediately after the first set of nails is applied in each row.

5.3.4 If necessary, the first set of nails in each row shall be redriven after the second set of nails has been driven.

5.3.5 Single nails shall be used on the perimeter of the gypsum panel product.

5.4 Screws shall be spaced not more than 12 in. (300 mm) o.c. for ceilings and 16 in. (400 mm) o.c. for walls where the framing members are 16 in. (406 mm) o.c. Screws shall be spaced not more than 12 in. (300 mm) o.c. for both ceilings and walls where framing members are 24 in. (610 mm) o.c.

5.5 A combination of fasteners consisting of nails along the perimeter and screws in the field of the gypsum panel product shall be permitted to be used. The spacing between a nail and an adjacent screw shall be not more than the spacing specified for screws in Section 5.4.

6. Application of Multi-Layer Gypsum Panel Products to Wood Framing Members.

6.1 Spacing of framing members for multi-layer gypsum panel product systems shall be as specified in Tables 2 and 3.

6.2 The base and face layers of gypsum panel products shall be applied with fasteners of the size and type specified in Sections 2 and 5 and Table 5 and shall be spaced as specified in Table 6.

6.3 When adhesive is not used between layers, the gypsum panel products shall be applied as specified in Table 2.

6.3.1 Nails and screws for applying the face layer shall be spaced as specified in Sections 5.2 through 5.5 for single-layer systems.

6.4 When adhesive is used between layers, the gypsum panel products shall be applied as specified in Table 3.

6.4.1 Adhesive shall be evenly applied over the face of the base layer, or over the back of the face layer of the gypsum panel product before it is erected, using the type

of adhesive and method of application specified by the gypsum panel product manufacturer.

6.4.2 The face layer of gypsum panel products applied to walls shall be placed in position and attached with a sufficient number of nails or screws to hold the gypsum panel products in place until adhesive bond develops. As an alternate to nails or screws, the second layer of gypsum panel products shall be held in position by temporary fasteners or by shoring with props and headers or other temporary supports until adhesive bond develops.

6.4.2.1 Unless otherwise specified by the gypsum panel product manufacturer, permanent fasteners spaced not more than 16 in. (400 mm) o.c. shall be used at the top and bottom plates. Permanent nails or screws shall be of sufficient length to penetrate into framing members not less than as specified in Table 5.

6.4.3 Unless otherwise specified by the gypsum panel product manufacturer, permanent nails or screws spaced not more than 12 in. (300 mm) o.c. around the perimeter and 16 in. (400 mm) o.c. in the field shall be used on ceilings. Permanent nails or screws shall be of sufficient length to penetrate into framing members not less than as specified in Table 5.

7. Adhesive Application to Wood Framing Members.

7.1 Except as herein modified, application shall be in accordance with Section 5.

7.2 Gypsum panel products and framing member surfaces to be adhered by adhesive shall be dry and free from dust, dirt, grease, or other foreign matter that impairs bond.

7.3 A bead of adhesive not less than 3/8 in. (10 mm) in diameter shall be applied to the face of all framing members, except top and bottom (sole) plates, that are to support the gypsum panel product. When the gypsum panel product is placed, the adhesive beads shall spread to an average width of 3/4 in. (19 mm) and approximately 1/16 in. (1.5 mm) thick. (See Figure 10.)

7.3.1 Where an end or edge joint occurs on a framing member, two parallel beads of adhesive not less than 3/8 in. (10 mm) in diameter shall be applied, one near each edge of the framing member. (See Figure 10.)

Figure 10
Adhesive application patterns

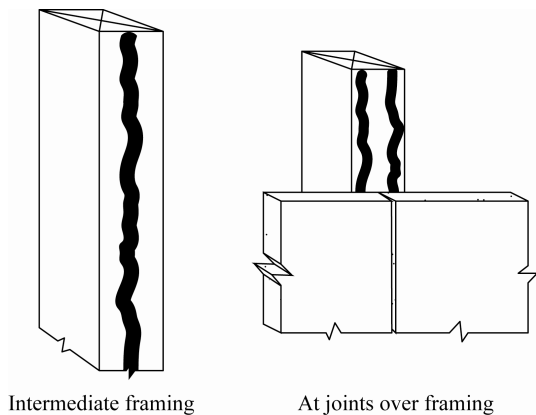

7.3.2 Adhesive shall be applied to no greater area than is to be covered with gypsum panel product within the open time of the adhesive.

7.4 On ceilings, or if adhesive properties are such that there is no positive bridging between the gypsum panel product and the wood framing, either temporary field nailing or temporary bracing shall be provided as required to assure contact between the gypsum panel product, the adhesive, and the framing face until adhesive bond develops. Unless otherwise specified by the manufacturer of either the gypsum panel product or the adhesive, fastener spacing shall be as specified in Table 7.

7.5 If adhesive properties are such as to assure bridging between the gypsum panel product and the framing members, mechanical fastening shall not be required in the field of the panel product for walls. Perimeter fastening shall be permitted.

7.6 When used, a two-component catalyzed foam type adhesive shall be applied to the back side of the gypsum panel product, filling the angle formed by the gypsum panel product and the framing member. Mechanical fasteners shall not be required. The adhesive manufacturer's specifications shall be followed for application, use, and required curing.

8. Gypsum Panel Product Application over Steel Framing and Furring.

8.1 Steel framing and furring to which gypsum panel products are to be applied shall be spaced as specified in Table 1 for single-layer gypsum panel product systems and in Tables 2 and 3 for multi-layer gypsum panel product systems.

8.2 To provide a more level surface at joints, arrange gypsum panel product application so that the leading edge of each panel product is attached to the open or unsupported edge of the steel stud flange. (See Figure 11.)

Figure 11
Direction of gypsum panel product application to steel framing

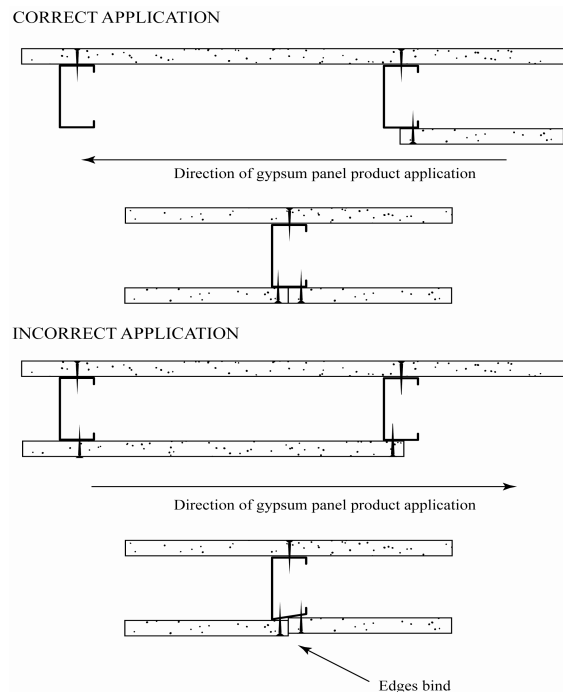

8.3 Screws shall be of sufficient length to penetrate framing members not less than 3/8 in. (10 mm).

8.3.1 Where resilient furring channels are used over wood or steel framing, the screws used to attach the gypsum panel product to the furring channels shall not contact the framing.

8.4 Screws for single-layer gypsum panel product systems and for the face layer in multi-layer gypsum panel product systems with no adhesive shall be spaced as specified in Section 5.4.

8.5 Screws for parallel application of base layers in multi-layer gypsum panel product systems with no adhesive between layers shall be spaced as specified in Table 6.

8.6 Screws for perpendicular application of base layers in multi-layer gypsum panel product systems with no adhesive between layers shall be located with one screw at each edge at each stud or furring channel intersection and one screw midway between the edges at each stud or furring channel.

8.7 Screws for either perpendicular or parallel application of base layers in multi-layer gypsum panel product systems with adhesive between layers shall be spaced as specified in Section 5.4.

8.8 Screws for the face layer in multi-layer gypsum panel product systems with adhesive between layers on ceilings shall be spaced not more than 12 in. (300 mm) o.c. along perimeter and not more than 16 in. (400 mm) o.c. in the field.

8.8.1 Screws for the face layer in multi-layer gypsum panel product systems with adhesive between layers on walls shall be of sufficient number to hold the gypsum panel product in place until adhesive bond develops. As an alternate to screws, the face layer of gypsum panel products shall be held in position by temporary fasteners or braced with temporary supports until adhesive bond develops.

9. Semi-Solid Gypsum Panel Product Partitions.

9.1 Face layer shall be 1/2 in. (12.7 mm) or 5/8 in. (15.9 mm) gypsum panel product or multiple layers of laminated gypsum panel products.

9.2 Runners shall be either wood runners, or steel channels or angles, of a width equal to the partition cavity.

9.2.1 Floor runners and ceiling runners shall be securely attached with fasteners spaced not more than 24 in. (600 mm) o.c.

9.2.2 Either runners or gypsum studs shall be installed vertically at required locations such as exterior walls, partition junctions, terminals, outside corners, and door frames.

9.2.3 Where partitions are located parallel to and between ceiling framing members, steel or wood headers spaced not more than 24 in. (610 mm) o.c. shall be provided for ceiling runner attachment prior to application of gypsum panel products to the ceiling.

9.3 Openings in or changes in direction of partitions shall be reinforced with additional gypsum studs laminated in place where specified in 9.3.1 through 9.3.3.

9.3.1 Outside Corners. A vertical gypsum stud shall be located between the face panels in the corner opposite vertical runners.

9.3.2 Abutting Walls. A vertical gypsum stud shall be located between the face panels of a partition at the intersection of an abutting wall.

9.3.3 Door Openings. A vertical gypsum stud shall be located not more than 3 in. (75 mm) from door frames, and a gypsum stud shall be placed horizontally over the door header.

9.4 Gypsum studs spaced not more than 24 in. (610 mm) on center shall be laminated to the face layer and shall be located at face layer vertical joints and at the vertical center line of each gypsum panel product in the face layer.

9.4.1 Gypsum studs shall be laminated to face panels either prior to erection or as erection of partition proceeds.

9.4.2 Laminating adhesive shall be evenly applied over the face of the gypsum studs so that it will cover approximately three-fourths of the gypsum stud surface after lamination.

9.5 The face layer gypsum panel products shall be oriented parallel to the gypsum studs. A starter face panel shall be erected vertically at an exterior wall. The starter panel shall be plumb and shall be secured to floor, ceiling, and vertical runners.

9.6 The next face panel shall be erected adjacent to the starter panel, butting its edge and end firmly to both the starter panel and the ceiling. Erection of face panels continues progressively, laminating exposed faces of the gypsum studs as the work progresses.

9.7 Type G screws spaced not more than 36 in. (900 mm) o.c. shall be used as required to ensure continuous contact between the gypsum panel product face panels and the gypsum studs.

10. Solid Gypsum Panel Product Partitions.

10.1 Face layers shall be 1/2 in. (12.7 mm) or 5/8 in. (15.9 mm) gypsum panel product or multiple layers of laminated gypsum panel products.

10.2 Core shall be either 1 in. (25.4 mm) thick gypsum coreboard, gypsum shaftliner board, or multiple layers of gypsum panel products laminated to the specified thickness.

10.3 Runners shall be wood runners or steel channels or angles.

10.3.1 Floor runners and ceiling runners shall be securely attached with fasteners spaced not more than 24 in. (600 mm) o.c.

10.3.2 Runners shall be installed vertically at required locations such as exterior walls, outside corners, and door frames.

10.3.3 Where partitions are located parallel to and between ceiling framing members, steel or wood headers spaced not more than 24 in. (610 mm) o.c. shall be provided for ceiling runner attachment prior to application of gypsum panel products to the ceiling.

10.4 Face layers shall be attached 24 in. (600 mm) o.c. to both floor and ceiling runners.

10.5 The 1 in. (25.4 mm) gypsum core shall be permitted to be installed prior to the installation of the face layers.

10.5.1 When steel angles are used as runners, the core shall be attached to the steel angles with not less than two evenly spaced fasteners per board, spaced not more than 24 in. (610 mm) o.c. When steel channels are used as runners, attachment of the core shall not be required. Using combinations of wood and steel channels or angles will vary the installation procedures.

10.6 Laminating adhesive shall be evenly applied over the face of the core, or over the back of the face layer gypsum panel products before they are erected, using the type of adhesive and method of application specified by the gypsum panel product manufacturer.

10.6.1 The face layer gypsum panel products shall be placed in position and attached with a sufficient number of nails or screws to hold the gypsum panel products in place until adhesive bond develops. As an alternate to nails or screws, the face layer of gypsum panel products shall be held in position by temporary fasteners or by shoring with props and headers or other temporary supports until adhesive bond develops.

10.7 Face layer joints shall be offset from the joints in the core.

11. Adhesive Application of Gypsum Panel Products to Interior Masonry, Concrete, or Brick Walls.

11.1 Only interior masonry, concrete, or brick walls above grade shall be acceptable masonry substrates for direct adhesive application.

11.2 Masonry, concrete, or brick surfaces to which gypsum panel products are to be adhesively applied shall be free from foreign matter, projections, or depressions that will impair bond.

11.3 Unless otherwise specified by the gypsum panel product manufacturer, adhesive shall be applied either to the back surface of the gypsum panel product or to the wall in continuous beads spaced not more than 12 in. (300 mm) o.c. or daubs spaced not more than 12 in. (300 mm) o.c. Beads shall be not less than 3/8 in. (10 mm) in diameter; daubs shall be not less than 2 in. (50 mm) in diameter by 1/2 in. (13 mm) thick with a row centered at all vertical gypsum panel product joints.

11.3.1 Gypsum panel products shall be positioned to provide a tight fit at abutting edges or ends. Do not slide panels. Mechanical fasteners or temporary bracing shall be used as required to support the gypsum panel products until adhesive bond develops.

11.3.2 Joint treatment shall not be applied until gypsum panel product is firmly bonded.

12. Application of Gypsum Panel Products to Flat Wall Insulating Concrete Form (ICF) Systems.

12.1 Except as herein modified, gypsum board application shall be in conformance with Section 4.

12.2 Control joints shall be as specified in Section 4.7.

12.3 *Plastic and metal attachment strips:*

12.3.1 Cross-tie flanges shall be embedded in the ICF and shall be vertically oriented.

12.3.2 Maximum spacing of the cross-tie flanges shall be 12 in. (300 mm) on centers.

12.4 Vertical joints in gypsum panel products shall be located midway between and attached to adjacent cross-tie flanges. (See Figure 12.)

Figure 12
Typical gypsum panel vertical joint location relative to Insulating Concrete Form cross ties

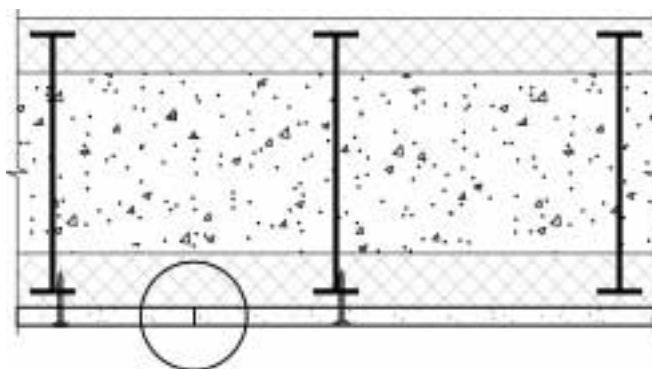

12.4.1 The distance between the joint and the cross-tie flange shall be not greater than 6 in. (150 mm).

12.5 Screws:

12.5.1 Gypsum panel products shall be attached to plastic ICF cross-tie flanges with Type S or W drywall screws and to metal cross-tie flanges with Type S drywall screws.

12.5.2 Screws shall be of sufficient length so that the threaded portion shall penetrate not less than 3/8 in. (10 mm) into the cross-tie flange.

12.5.3 Screws shall not penetrate completely to the concrete.

12.6 Screw Spacing:

12.6.1 Screw spacing for single-ply gypsum panel products and face ply of two-ply gypsum panel products over ICF with no adhesive shall be in accordance with 5.4.

12.6.2 Screw spacing for parallel applied base-ply of two-ply gypsum panel products over ICF with no adhesive between the plies shall be not more than 12 in. (300 mm) on centers into the cross-tie flanges on either side of vertical joints and 24 in. (610 mm) on centers into the cross-tie flanges in the field of the gypsum panel product.

12.6.3 The perpendicularly applied base-ply of two-ply gypsum panel products over ICF with no adhesive between the plies shall be attached to the cross-tie flanges with not less than one screw 24 in. (600 mm) on centers along each edge of the gypsum panel product and an additional row of screws spaced 24 in. (600 mm) midway between the edges.

12.6.4 Screw spacing for perpendicular or parallel applied base-ply of two-ply gypsum panel products over ICF with EPS compatible adhesive between plies shall be not more than as specified for single-ply gypsum panel products in 5.4.

12.6.5 On wall surfaces with adhesive between the plies, the face-ply shall have a sufficient number of screws to hold gypsum panel product in place.

Figure 13
Shimmed plaster wall

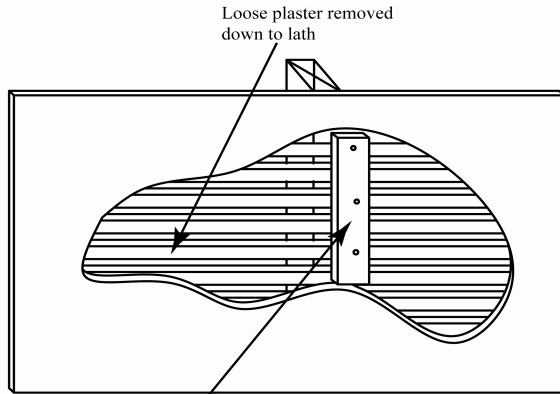

Shim same thickness as plaster secured through the lath into the framing with fasteners not more than 6" (150 mm) o.c.

13. Application of Gypsum Panel Products over Existing Interior Walls and Ceilings.

13.1 All loose plaster and wallpaper shall be removed from existing wall or ceiling surfaces to which gypsum panel products are to be applied.

13.2 Where wall or ceiling surfaces are either uneven or unsound, the entire existing surface shall be removed or furring channels shall be applied over the surface. (See Section 13.6)

13.2.1 Furring shall be applied as described in Sections 4.1.3 through 4.1.8. Fastener lengths shall be increased by the thickness of the existing surface over which the furring is applied.

13.3 Where more than 50 percent of the wall or ceiling surface is removed, the entire surface shall be removed and gypsum panel products shall be applied as if for new construction.

13.4 Voids and areas resulting from the removal of loose plaster shall be shimmed to the same thickness as the plaster to provide properly spaced backing for the new gypsum panel products. (See Figure 13.)

13.4.1 Wood shims shall be not less than 1 1/2 in. (38 mm) in width. Shims fabricated from gypsum panel products shall be not less than 2 in. (50 mm) in width.

13.4.1.1 In wood frame systems, shims shall be located over and attached to framing members with screws or nails spaced not more than 6 in. (150 mm) o.c.

13.4.1.2 In steel frame systems, shims shall be located over and attached to framing members with screws spaced not more than 6 in. (150 mm) o.c.

13.4.1.3 In masonry, concrete, or brick systems, shims shall be attached to the surface with masonry nails or an adhesive specifically designed for this purpose.

13.5 Gypsum panel products applied directly to existing wall and ceiling surfaces shall be attached with nails, screws, or staples or with adhesives in combination with nails, screws, or staples.

13.5.1 Gypsum panel products shall be attached directly over sound wall and ceiling surfaces with nails or screws. Framing members shall be sound, rigid, and aligned and shall be spaced not more than 16 in. (406 mm) o.c. for 3/8 in. (9.5 mm) thick gypsum panel products or 24 in. (610 mm) o.c. for 1/2 in. (12.7 mm) or 5/8 in. (15.9 mm) thick gypsum panel products. 1/4 in. (6.4 mm) and 5/16 in. (7.9 mm) thick gypsum panel products shall only be used for direct application to sound walls that are flat, level, and without void spaces.

13.5.1.1 Nail Application - Nails shall be of sufficient length to penetrate into wood framing not less than 7/8 in. (22 mm). Nails shall be spaced not more than 8 in. (200 mm) o.c. for walls and 7 in. (180 mm) o.c. for ceilings.

13.5.1.2 Screw Application - Screws shall penetrate into wood framing not less than 5/8 in. (16 mm) and steel framing not less than 3/8 in. (10 mm). Screw spacing shall be not more than 16 in. (400 mm) o.c. for walls and 12 in. (300 mm) o.c. for ceilings where framing members are not more than 16 in. (406 mm) o.c. and 12 in. (300 mm) o.c. for walls and ceilings where framing members are not more than 24 in. (610 mm) o.c.

13.5.2 Where the adhesive nail-on application method is used, a test shall be made in accordance with 13.5.2.1 and 13.5.2.2 to ensure that adhesive bond to the surface will be adequate.

13.5.2.1 Loose paper or wallpaper shall be removed from the plaster and the adhesive applied directly to a sound surface. Apply a single 3/8 in. by 3 in. (10 by 75 mm) bead of adhesive to an 8 in. (200 mm) square sample of gypsum panel product and press the sample to the surface. Repeat this in several widely spaced locations.

13.5.2.2 Allow sufficient setting time (see adhesive manufacturer's recommendations). Adhesive bond is tested by pulling the sample away from the surface. Bond is considered to be adequate if the back surface of the gypsum panel is torn from the specimen.

13.5.2.3 When it has been determined that bond strength is adequate, gypsum panel products shall be applied as described in Sections 6 and 7.

13.6 Attachment using furring channels.

13.6.1 Preparation for attachment using furring members.

13.6.1.1 Bulges in the old surface that interfere with the application of furring shall be removed so furring is tight against the surface and the face of the furring is level across the wall or ceiling.

13.6.1.2 Existing trim need not be removed if the new furred out surface will cover these items.

Figure 14
Gypsum panel product substrate under rigid pre-decorated combustible panel

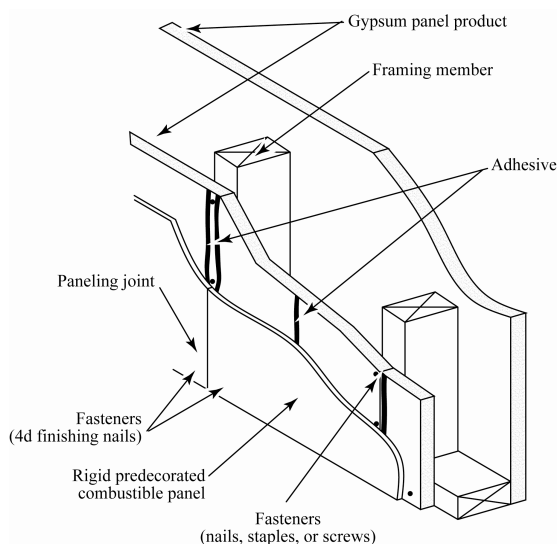

13.6.1.3 Furring shall be terminated not less than 6 in. (150 mm) from any trim member. Shims shall be used to level the surface.

13.6.2 As an alternate to direct attached furring on ceilings, a system of suspended wood furring, suspended steel furring channels, or a grid suspension system shall be used.

14. Gypsum Panel Product Application over Rigid Plastic Foam Insulation.

14.1 Gypsum panel products shall be applied over rigid plastic foam insulation installed on wood or steel wall framing or on the interior side of exterior masonry and concrete walls to provide a wall finish and protect the insulation from early exposure to fire from within the building.

14.1.1 The entire insulated wall surface shall be protected with gypsum panel products, including walls above ceilings and in unoccupied spaces.

14.2 Nails, screws, and staples shall be spaced as specified in Sections 5 through 8.

14.2.1 Nails, screws, and staples shall be of sufficient length to penetrate wood framing and furring members not less than as specified in Table 5.

14.2.2 Screws shall be of sufficient length to penetrate steel framing and furring members not less than as specified in Section 8.3.

14.3 Steel or Wood Framed Walls.

14.3.1 A single- or multi-layer of either 1/2 in. (12.7 mm) or 5/8 in. (15.9 mm) thick gypsum panel products shall be attached with mechanical fasteners through the rigid foam insulation to the framing members.

14.4 Masonry, Concrete, or Brick Walls.

14.4.1 A single- or multi-layer of either 1/2 in. (12.7 mm) or 5/8 in. (15.9 mm) thick gypsum panel products shall be attached to steel or wood wall furring members that are attached to the wall vertically and in accordance with the furring manufacturer's specifications.

14.4.2 Furring members to which gypsum panel products are to be attached shall be designed to minimize thermal transmission.

14.4.3 Single-layer gypsum panel products shall be applied parallel to the furring members with vertical joints located over furring members. Gypsum panel products shall be placed so that horizontal butt joints are minimized.

14.4.4 In multi-layer systems, base layers shall be applied vertically. Face layer joints shall be offset from base layer joints a distance of not less than the spacing between furring members.

14.5 In single-layer systems, all joints between gypsum panel products shall be finished to a minimum Level 2 as described in GA-214, *Recommended Levels of Gypsum Board Finish*.

14.6 In multi-layer systems, base layers shall not be required to be finished. Face layer joints shall not be required to be finished unless required for decoration.

14.7 Vinyl faced gypsum panel products shall not be adhesively applied to rigid plastic foam insulated walls.

15. Application of Rigid Predecorated Combustible Panels (Paneling) to Gypsum Substrate.

15.1 Where required for added rigidity, fire resistance, or sound control, gypsum panel products shall be used as a substrate for rigid predecorated combustible paneling. (See Figure 14.)

15.2 Gypsum panel products shall be applied as specified in Section 6 for the base layer in multi-layer systems with adhesive between layers.

15.3 Rigid predecorated combustible paneling shall be applied as specified by the paneling manufacturer. Paneling joints shall be offset from gypsum panel product joints.

16. Application of Gypsum Panel Products to Receive Adhesively Applied Ceramic or Plastic Wall Tile or Plastic Finished Wall Panels.

Note 5: Consult gypsum panel product manufacturer for recommendations regarding the use of specific gypsum panel products as a base for tile in wet areas.

Note 6: The use of water-resistant gypsum backing board as a base for tile in wet areas is regulated by local codes. Consult local building codes for requirements.

16.1 Framing around tub enclosures and shower stalls shall be located to permit the inside lip of the tub, prefabricated receptor, or hot-mopped sub-pan to be aligned with the face of the gypsum panel product. (See Figures 15, 16, and 17.)

16.1.1 Where framing is spaced more than 16 in. (406 mm) o.c., blocking or backing shall be provided approximately 1 in. (25 mm) above the top of the tub or receptor and at gypsum panel product horizontal joints in the area to receive tile.

16.1.2 Interior angles shall be framed or blocked to provide solid backing for interior corners.

16.1.3 Blocking, headers, or supports shall be provided to support the tub and other plumbing fixtures and to receive soap dishes, grab bars, towel racks, and similar items.

16.1.4 Waterproof receptors, pans, or sub-pans shall have an upstanding lip or flange not less than 1 in. (25 mm) higher than the water dam or threshold contained in the entry way to shower.

16.2 Where ceramic tile is to be installed over the gypsum panel products steel studs shall be not less than 0.033 in. (0.84 mm) base metal thickness and shall be not less than 3-1/2 in. (89 mm) deep for residential applications, or not less than 3-5/8 in. (92 mm) deep for commercial applications, and shall be spaced not more than 16 in. (406 mm) o.c.

16.3 Either water-resistant gypsum backing board or glass mat water-resistant gypsum backing panels shall be used as a base for the application of ceramic or plastic wall tile or plastic finished wall panels in wet areas such as tub and shower enclosures. Regular gypsum panel products shall be permitted to be used as a base for tile and wall panels in dry areas.

Note 7: The only gypsum panel product permitted to be used as a base for tile in wet areas in the 2006 and later Editions of the International Building Code and the International Residential Code is Coated Glass Mat Gypsum Panels complying with ASTM C1178/C1178M.

16.3.1 Gypsum panel products used as a base for tile or wall panels in wet areas shall not be foil-backed and shall not be applied over any vapor retarder.

16.3.1.1 For the purposes of this specification, a single layer of asphalt impregnated felt, #15 or less, applied as part of the wall system, shall not be considered a vapor retarder.

16.4 Adhesive for the application of surfacing material to gypsum panel products shall be as specified by the surfacing material manufacturer.

16.5 Water-resistant gypsum panel products shall be applied in a perpendicular application with the factory edge spaced a minimum of 1/4 in. (6 mm) above the lip of the receptor, tub, or sub-pan. (See Figures 15, 16, and 17.) Shower pans, receptors, or tubs shall be installed prior to the application of the gypsum panel products.

16.5.1 For fire or sound rated systems, the gypsum panel products required for the fire or sound rating shall extend full height, floor to ceiling. (See Figure 17 and GA-600, *Fire Resistance Design Manual*)

Figure 15
Typical details – tub installation

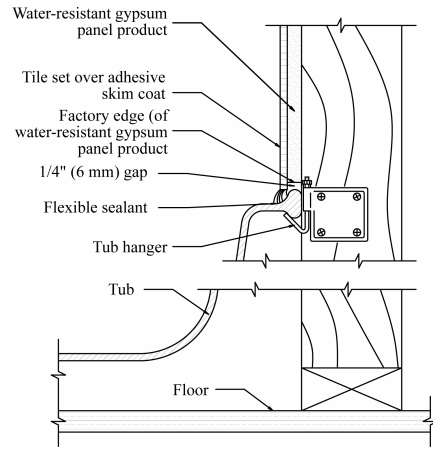

Figure 16
Typical details – shower pan installation

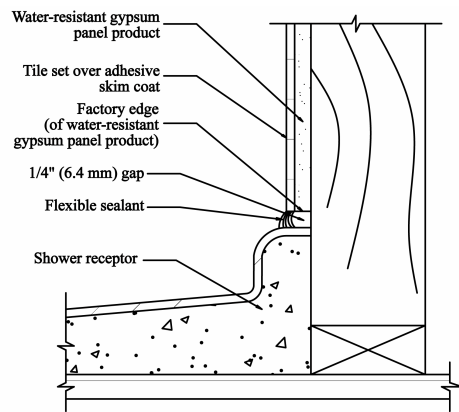
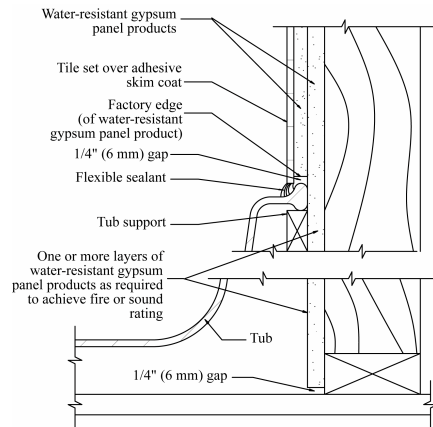

Figure 17
Typical details – tub installation in fire-rated or sound-rated system



16.5.2 In areas to receive tile, water-resistant gypsum backing board or glass mat water-resistant gypsum backing panels shall be attached with nails or screws spaced not more than 8 in. (200 mm) o.c. Gypsum panel products applied using adhesive only shall not be used as a base to receive tile.

16.5.3 Joints and fastener heads shall be finished to a minimum Level 2 as described in GA-214, *Recommended Levels of Gypsum Board Finish*.

16.5.4 Where ceramic, plastic, or metal wall tile or plastic finished rigid wall panels or other types of surfacing materials are to be applied over gypsum panel products in either wet or dry areas, the specifications of the tile, wall panel, or other surfacing material manufacturer shall be followed.

16.5.4.1 For more specific details see Appendix A.2.

Note 8: To maintain tile system integrity, periodic maintenance of grout, caulking, and sealants at penetrations is required. Failure to properly maintain these essential system components can result in water intrusion and subsequent damage to the system.

17. Outside Corners, Arches, and Curves.

17.1 Outside corners shall be protected with a metal or plastic bead or other suitable type of corner protection attached to the supporting construction with fasteners spaced not more than 9 in. (230 mm) o.c. Metal corner bead shall be permitted to be attached with a crimping tool not more than 6 in. (150 mm) o.c. Paper faced corner bead shall be attached with joint compound.

17.2 Where gypsum panel products are to be applied to curved soffits of arches, they shall be carefully bent into place. (See Table 8 and/or GA-226 *Application of Gypsum Board to Form Curved Surfaces*)

17.2.1 To apply gypsum panel products, a stop shall be placed at one end of the curve. One end of the gypsum panel product shall be positioned against the stop. Gentle and gradual pressure shall be applied to the unrestrained end of the gypsum panel product, forcing the center of the gypsum panel product against the framing until the curve is complete.

17.2.2 To prevent flat spots on the curved surface, framing members shall be spaced closer together than required for typical flat wall or ceiling surfaces. For minimum radius bends, framing spacing shall be not greater than 6 in. (150 mm) on center.

17.3 Where scoring or moistening the gypsum panel product is necessary to apply gypsum panel product to radii shorter than those shown in Table 8 such scoring or moistening shall be as specified either in Section 17.3.1 or Section 17.3.2.

17.3.1 Scoring: The gypsum panel product shall be scored approximately 1 in. (25 mm) o.c. on back side. After the core has been snapped at each cut, the gypsum panel product shall be applied to the curved surface and anchored in place with nails or screws.

Table 8
Bending Radii*

Gypsum Board Thickness in. (mm)	Bent Lengthwise ft (mm)	Bent Widthwise ft (mm)
1/4 (6.4)	5 (1500)	15 (4600)
3/8 (9.5)	7.5 (2300)	25 (7600)
1/2 (12.7)**	10 (3000)	Not Recommended
5/8 (15.9)	15 (4600)	Not Recommended

* For tighter radii see Section 17.3.
** Bending two 1/4 in. (6.4 mm) pieces successively permits radii shown for 1/4 in. (6.4 mm).

17.3.2 Moistening: Evenly spray water on the surface which will be in tension when the gypsum panel product is hung such that the water is allowed to soak into the core before application. The gypsum panel product must be dried within 24 hours of wetting. Fans and mechanical dehumidification should be used to accelerate drying when conditions are not conducive to natural drying. When the gypsum panel product dries thoroughly, its original hardness is regained.

17.4 Joint compound and either joint tape or corner bead, as appropriate, shall be applied to inside or outside corners of arches, formed by adjoining angle surfaces. Joint tape or corner bead shall be snipped at intervals along one side to conform to the curve.

18. Exterior Applications of Exterior Gypsum Soffit Board or Gypsum Panel Products.

18.1 Exterior gypsum soffit board, or gypsum panel products intended for such use 1/2 in. (12.7 mm) or 5/8 in. (15.9 mm) thick shall be used for ceilings of carports, open walkways, porches, and soffits of eaves that are either horizontal or inclined downward away from the building.

18.1.1 Adequate ventilation shall be provided for space immediately above gypsum panel products as specified in Section 1.6. (See Figure 18.)

18.2 Framing shall be spaced not more than 16 in. (406 mm) o.c. for 1/2 in. (12.7 mm) thick gypsum panel products and not more than 24 in. (610 mm) o.c. for 5/8 in. (15.9 mm) thick gypsum panel products.

18.3 The gypsum panel product shall be applied in a perpendicular application and as specified for ceiling applications in Sections 5 through 8.

18.3.1 Unless protected by metal or other water stops, the edges of the gypsum panel product shall be spaced not less than 1/4 in. (6 mm) away from abutting vertical surfaces.

18.3.2 Joints and fastener heads shall be treated with a setting-type joint compound.

Figure 18
Typical soffit details

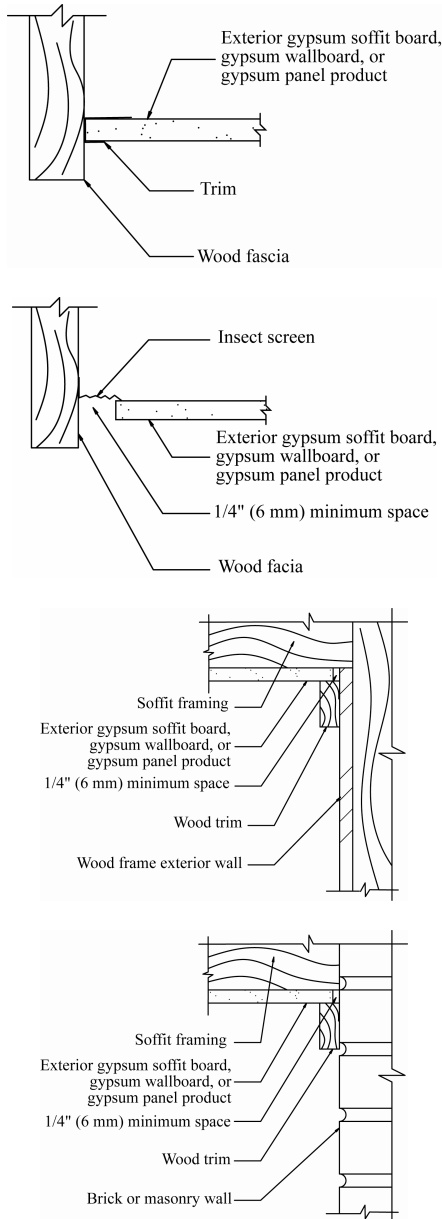

18.4 Exterior gypsum soffit board shall be taped and finished as described in 18.4.1 and 18.4.2.

18.4.1 Joints shall be taped and finished using either paper or glass mesh tape.

18.4.2 Joints and fastener heads shall be treated with setting-type joint compound.

18.5 Gypsum panel products, other than gypsum soffit board, used on exterior soffits shall be taped and finished as described in 18.5.1 through 18.5.2.

18.5.1 Joints shall be taped with glass mesh tape.

18.5.2 Joints and fastener heads shall be treated with setting-type joint compound.

18.6 Facia and molding shall be provided around the perimeter to protect gypsum panel products from direct exposure to water.

18.6.1 Exposed surfaces of gypsum panel products shall be painted with not less than a prime coat and two coats of exterior paint.

18.7 Gypsum board lay-in panel manufacturer's specifications shall be followed for the use of gypsum lay-in panels.

19. Electric Radiant Heating Systems for Gypsum Panel Product Ceilings.

19.1 Where gypsum panel products are to be used in conjunction with radiant heat ceiling systems, details of construction shall be in accordance with ASTM C1546, *Standard Guide for the Installation of Gypsum Products in Concealed Radiant Ceiling Heating Systems*.

19.2 Under operating conditions, gypsum panel products shall not be exposed to sustained temperatures exceeding 125°F (52°C).

19.3 See Table 9 for thermal performance values of gypsum board.

20. Finishing Gypsum Panel Products.

Note 9: Base layer joints and fasteners in multi-layer systems are not required to be taped or finished.

20.1 Compounds for taping and finishing shall be either drying- or setting-type. Different types of compound shall not be mixed with one another unless recommended by the joint compound manufacturer.

20.1.1 Care shall be taken to ensure that all tools and containers are kept clean and free from foreign materials. Only potable water shall be used for mixing powder compounds or to thin premixed materials. Once setting materials have been mixed, no additional water shall be added. Compounds shall not be allowed to freeze.

20.1.1.1 Approved protective respirators shall be worn when mixing powder or when sanding. Mixing shall be done according to manufacturer's directions. Mixer speeds shall not exceed those specified by joint compound manufacturer.

Thickness in. (mm)	Conductance "C" Btu/ft ² ·h·°F (W/K.m ²)	Resistance "R" °F·h·ft ² /Btu (K.m ² /W)
3/8 (9.5)	3.03 (17.2)	0.33 (0.058)
1/2 (12.7)	2.22 (12.6)	0.45 (0.079)
5/8 (15.9)	2.08 (11.8)	0.48 (0.085)
3/4 (19.0)	1.67 (8.3)	0.64 (0.12)
1 (25.4)	1.20 (6.3)	0.83 (0.16)

20.1.2 When applied, joint compounds shall be compatible with previous coats.

20.2 Adequate and continuous ventilation shall be provided to ensure proper drying, setting, or curing of taping and finishing compounds.

20.2.1 Drying-type compounds shall be allowed to dry thoroughly (see Table 1 in GA-236, *Joint Treatment Under Extreme Weather Conditions*) before sanding (See Section 20.1.1.1) or the application of additional coats.

20.2.2 Setting-type compounds shall be permitted to receive additional coats as soon as material has set and before it dries completely.

20.3 Gypsum panel products shall be kept free of dirt, oil, or other foreign matter that causes a lack of bond of joint compound. All dents, gouges, recesses, or other depressions shall be filled with compound and drawn to a level plane. All joints shall be even and true (See Section 4.6.7). Panels shall be tight against framing members.

20.4 Taping and finishing shall be done using the hand tools designed for this purpose, such as broad knives or trowels with straight and true edges, or mechanical tools designed for this purpose.

20.5 Joint tape shall be applied as described in Sections 20.5.1, 20.5.2, or 20.5.3.

20.5.1 Paper tape shall be applied by applying joint compound to the joint (buttering), centering and pressing in the paper tape and wiping off the excess compound, or by mechanical tools designed for this purpose. Sufficient compound shall be left under the paper tape to bond the paper tape to the gypsum panel product.

20.5.2 Self-adhering glass mesh tape shall be applied to clean, dry gypsum panel products by centering the tape over the joint and pressing the tape firmly to ensure proper adhesion. A coat of setting-type joint compound shall be applied over the tape and forced through the mesh so that it fills the joint in the underlying gypsum panel products and completely hides the weave of the glass mesh tape.

20.5.3 Glass mesh tape that is not self-adhering shall be applied and held in place with a corrosion resistant staple. A coat of setting-type joint compound shall be applied over the tape and forced through the mesh to fill the joint in the underlying gypsum panel products and completely hide the weave of the glass mesh tape.

20.6 The second coat shall be applied with tools of sufficient width to extend approximately 3 1/2 in. (90 mm) beyond the center of the joint center. Compound shall be drawn down to a smooth even plane.

20.6.1 After drying or setting, treated surfaces shall be sanded or otherwise smoothed as needed (See Section 20.1.1.1) to eliminate high spots or excess compound. When sanding the joints, care shall be taken not to raise the nap of the gypsum panel product surface.

20.7 Where a third coat is specified, it shall be applied with tools that will permit feathering of the joint treatment edges approximately 6 in. (150 mm) from the center of the joint.

20.7.1 After drying, the final coat shall be lightly sanded (See Section 20.1.1.1) with 120 grit or finer sandpaper or wiped with a damp sponge to leave a smooth even surface covering the joint. When sanding the joints, care shall be taken not to raise the nap of the gypsum board paper.

20.8 Fastener heads shall be covered with three coats, each applied in a different direction. Each coat shall be allowed to dry or set before subsequent coats are applied.

20.9 All cut-outs shall be back-filled with the compound used for taping or finishing so there is no opening larger than 1/4 in. (6 mm) between the gypsum panel product and the penetrating element.

20.9.1 All cut edges and openings around plumbing penetrations shall be caulked flush with water-resistant flexible sealant complying with ASTM C920, *Standard Specification for Elastomeric Joint Sealants*, Type S, Grade NS, Class 25.

20.10 All levels of finish shall be applied as specified by the designer appropriate to the final decoration. See GA-214, *Recommended Levels of Gypsum Board Finish*.

20.11 A good quality drywall primer shall be applied prior to decoration. (See Appendix Sections A.3.3 and A.4.3.1.)

APPENDIX

A.1 Precautions to Minimize Potential of Sagging.

A.1.1 Framing spacing shall be as specified in Tables 1 and 4. Gypsum panel products shall be applied perpendicular to the framing.

A.1.2 Excessive amounts of insulation shall not be added without additional support. (See Table 4.)

A.1.3 Relative humidity within the structure shall be controlled by ventilation or mechanical dehumidification.

Note 10: Activities such as pouring floors, water-based texturing, temporary heating with portable heaters, etc. may result in high humidity conditions that need to be addressed.

A.1.4 Gypsum panel products shall be thoroughly dry and at ambient temperature before application.

A.1.5 Joint treatment shall be thoroughly dry before applying any decoration. (See Table 1 in GA-236, *Joint Treatment Under Extreme Weather Conditions.*)

A.1.6 Individual coats of primer and paint shall be dry before the application of successive coats.

A.1.7 Where the gypsum panel product supports ceiling insulation and is finished with a water-based texture material only 5/8 in. (15.9 mm) gypsum panel products, or 1/2 in. (12.7 mm) gypsum ceiling board, applied perpendicular to the framing members shall be used. Where severe adverse conditions are anticipated, framing spacing shall be not more than 16 in. (406 mm) o.c.

A.2 Application of Ceramic or Plastic Wall tile or Plastic Finished Wall Panels over Gypsum Panel Products.

Note 11: The use of water-resistant gypsum backing board as a base for tile in wet areas is regulated by local codes. Consult local building codes for requirements.

A.2.1 Application of gypsum panel products under this specification shall be in accordance with the requirements of Section 16.

A.2.2 Following are recommendations for application of surfacing materials, when not in conflict with the specifications of the surfacing materials manufacturers.

A.2.2.1 Gypsum panel products to be covered with ceramic tile shall not be skim coated with joint compound.

A.2.2.2 Ceramic tile shall be installed in accordance with ANSI A108, *American National Standard Specification for the Installation of Ceramic Tile.*

A.2.2.3 The weight of ceramic tile applied directly over gypsum panel products using thin-set adhesive shall not exceed 6.5 psf (32 kg/m²).

A.2.2.4 A skim coat of adhesive complying with ANSI A136.1, *American National Standard for Organic Adhesives for Installation of Ceramic Tile, Type I or Type II*, shall be applied over all surfaces that have been finished with joint compound and shall be cured before the application of tile begins.

A.2.2.5 Cut edges and openings shall be sealed with a water-resistant flexible sealant to create a water repellant barrier where water-resistant gypsum panel products have been cut and the gypsum core is exposed. Sealant shall be as specified in A.1.2.5(a) through A.1.2.5(b) or equivalent.

(a) Ceramic tile adhesive complying with ANSI A136.1, *American National Standard for Organic Adhesives for Installation of Ceramic Tile, Type I or Type II.*

(b) Flexible sealant complying with ASTM C920, *Standard Specification for Elastomeric Joint Sealants, Type S, Grade NS, Class 25.*

A.2.2.6 Tile or wall panels shall be applied down to the top surface or edge of the finished shower floor, return, or tub and shall overlap the top lip of the receptor, sub-pan, or tub and shall completely cover the areas specified in Sections A.2.2.6(a) through A.2.2.6(e). (See Figure 19.)

(a) Tubs without showerheads - Surfacing material shall extend not less than 6 in. (150 mm) above the rim of the tub.

(b) Tubs with showerheads - Surfacing material shall extend not less than 5 ft (1500 mm) above the rim of the tub or 6 in. (150 mm) above the height of the showerhead, whichever is higher.

(c) Shower stalls - Surfacing material shall extend not less than 6 ft (1800 mm) above the shower dam or 6 in. (150 mm) above the height of the showerhead, whichever is higher.

(d) Gypsum panel product window sills and jambs in shower or tub enclosures shall be covered to a height not less than as specified for the wall.

(e) Surfacing material shall be applied to the full specified height for a distance of not less than 4 in. (100 mm) beyond the outside face of the tub or receptor. Areas beyond an outside corner are excluded.

A.2.2.7 Where plastic finished rigid wall panels are used as a surfacing material, the precautions in Sections A.2.2.7(a) through A.2.2.7(c) shall be followed.

(a) The type and shape of moldings specified by the surfacing material manufacturer shall be used. Specified tub moldings shall be used where the surfacing materials abut the tub, shower floor, or curb. Such moldings shall be set in water-resistant flexible sealant.

(b) Joints shall be filled in such a manner as to leave no voids for water penetration.

(c) A bead of water-resistive flexible sealant shall be applied as a dam between the back surface of the finishing material and the tub or receptor to prevent any leakage of water at the joint.

Note 12: To maintain tile system integrity, periodic maintenance of grout, caulking, and sealants at penetrations is required. Failure to properly maintain these essential system components can result in water intrusion and subsequent damage to the system.

Figure 19
Tile in bath and shower should be brought up to the levels shown.

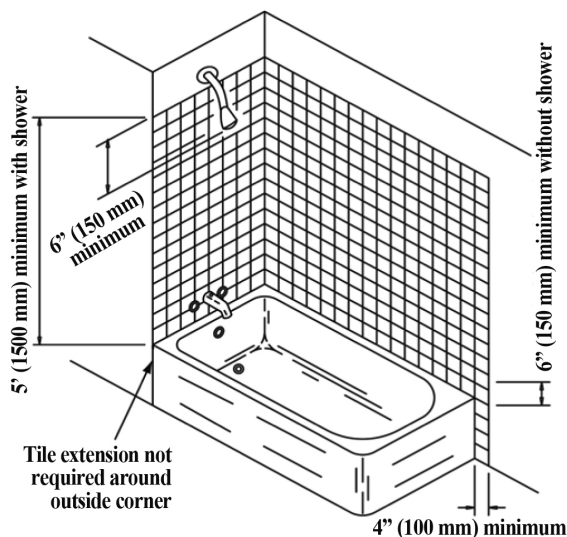

A.3 Application of Water-Based Texture Finishes on Gypsum Panel Product Ceilings.

A.3.1 When hand or spray-applied water-based texture finishes are to be used on gypsum panel product ceilings under this specification either i) 1/2 in. (12.7 mm) gypsum ceiling board shall be used perpendicular to framing or ii) the conditions specified in Sections A.3.1.1 or A.3.1.2 shall be met.

A.3.1.1 For framing spaced 16 in. (406 mm) o.c., 1/2 in. (12.7 mm) thick gypsum panel products shall be applied perpendicular to the framing members; 5/8 in. (15.9 mm) thick gypsum panel products shall be applied either perpendicular or parallel to the framing members. (See Tables 1 and 2.)

A.3.1.2 For framing spaced 24 in. (610 mm) o.c., 5/8 in. (15.9 mm) thick gypsum panel products shall be used and shall be applied perpendicular to the framing. (See Tables 1 and 2.)

A.3.2 Failure to comply with Tables 1 and 2 of this specification creates a potential for ceiling sag.

A.3.3 A drywall primer compatible with the texture material shall be applied prior to the application of any water-based texture.

A.3.4 Water-based textures in conjunction with one or more of the conditions described in Sections A.3.4(a) through A.3.4(f) create a potential for ceiling sag.

- (a) Unventilated building.
- (b) Use of vapor retarder(s) under certain conditions.
- (c) Prolonged high humidity due to either weather conditions or closed building units (poor drying conditions).
- (d) Inadequate framing support (can occur where framing changes direction).
- (e) Improper type or thickness of gypsum panel products.
- (f) Lack of proper primer.

A.4 Decoration of Gypsum Panel Products.

A.4.1 Decoration of gypsum panel products shall not proceed until the finishing materials, applied as specified in Section 18, are thoroughly dry.

A.4.2 Surfaces shall be clean and free of dust, dirt, oil, or other foreign matter. A damp sponge shall be used to remove dust prior to decoration.

A.4.3 Paint

A.4.3.1 Gypsum panel product surfaces intended to receive paint shall be primed prior to painting.

A.4.3.2 Drywall primer shall be compatible with the paint.

A.4.3.3 Where paint materials are to be applied with an airless sprayer, the sprayer manufacturer's and paint manufacturer's specifications shall be followed. Sprayed surfaces shall be back-rolled for best results.

A.4.4 Texture

A.4.4.1 Gypsum panel product surfaces intended to be textured shall be primed prior to the application of texture materials.

A.4.4.2 Drywall primer shall be compatible with the texture material.

A.4.4.3 Where texture materials are to be applied with an airless sprayer, the sprayer manufacturer's and texture manufacturer's shall be followed.

A.4.5 Wallcoverings

A.4.5.1 Gypsum panel products intended to be decorated with wallcoverings shall be sealed, and the sealant allowed to dry completely, prior to the application of wallcovering materials.

A.4.6 Ceramic Tile (See Appendix A.2).

GYPSUM ASSOCIATION MEMBERSHIP 2016

AMERICAN GYPSUM COMPANY LLC

CERTAINTEED GYPSUM, INC.

CERTAINTEED GYPSUM CANADA, INC.

CGC INC.

CONTINENTAL BUILDING PRODUCTS
OPERATING COMPANY, LLC

GEORGIA-PACIFIC GYPSUM LLC

NATIONAL GYPSUM COMPANY

PABCO® Gypsum

a division of PABCO® building products, LLC

UNITED STATES GYPSUM COMPANY



Gypsum Association
6525 Belcrest Road, Suite 480
Hyattsville, MD 20782

301.277.8686

Fax: 301.277.8747

info@gypsum.org

www.gypsum.org